



Strong. Smart. Beautiful.

T1X-03 (AC) TREADMILL SERVICE MANUAL

TABLE OF CONTENTS

CHAPTER 1: SERIAL NUMBER LOCATION	1
CHAPTER 2: IMPORTANT SAFETY INSTRUCTIONS	
2.1 Before Getting Started	2
2.2 Read and Save These Instructions	3
2.3 Electrical Requirements	4
CHAPTER 3: PREVENTATIVE MAINTENANCE	
3.1 Recommended Cleaning Tips	5
3.2 Check for Damaged Parts	5
3.3 Care and Maintenance Instructions	6
3.4 Auto Calibration Procedure	7
3.5 Adjusting the Running Belt	7
3.6 Knowing When to Replace the Running Belt and Deck	8
CHAPTER 4: USING THE CONSOLE AND PROGRAM DESCRIPTION	
4.1 Console Description	9
4.2 Manual Workout Operation	10
4.3 Operating Level Based Programs	10
4.4 Heart Rate Control Workout Operation	11
4.5 Fitness Test Workout Operation	11
CHAPTER 5: MANAGER MODE	
5.1 Using Manager Mode	13
5.2 Manager Mode Overview	13
CHAPTER 6: ENGINEERING MODE	
6.1 Using Engineering Mode	14
6.2 Engineering Mode Overview	14
CHAPTER 7: SERVICE MODE:	
7.1 Using Service Mode	15
7.2 Service Mode Overview	15
CHAPTER 8: TROUBLESHOOTING	
8.1 Electrical Diagram	16
8.2 MCB Wiring	19
8.3 MCB LED Placement and Definitions	20
8.4 Error Messages on the Console	21
8.5 0140 / 01A0 Error Troubleshooting	22
8.6 01A4 / 01A5 / 01A6 Error Troubleshooting	23
8.7 01A8 / 01AD / 02B6 / 02B7 / 02B5 Error Troubleshooting	24
8.8 01AB Error Troubleshooting	25
8.9 02A0 / 02A8 Error Troubleshooting	26
8.10 02A1 / 02A2 Error Troubleshooting	27
8.11 02AD Error Troubleshooting	28
8.12 02B5 Error Troubleshooting	29
8.13 02B9 / 02BA / 02BC / 02BD Error Troubleshooting	30
8.14 04A0 Error Troubleshooting	31
8.15 Troubleshooting - Heart Rate Issues	32
8.16 Entertainment Troubleshooting - Overview	33
8.17 Entertainment Troubleshooting - Picture Fuzzy or Unclear	34
8.18 Entertainment Troubleshooting - TV Will Not Turn On	35
8.19 Entertainment Troubleshooting - Controller Issues	36

CHAPTER 9: PART REPLACEMENT GUIDE

9.1	Motor Cover Replacement	37
9.2	Rear Roller Replacement	38
9.3	Deck Replacement	39
9.4	Deck Cushion Replacement	40
9.5	Front Roller Replacement	41
9.6	Running Belt Removal	42
9.7	Side Rail Replacement	43
9.8	Motor Control Board (MCB) Replacement	44
9.9	Motor Replacement.....	45
9.10	Drive Belt Replacement	47
9.11	Incline Motor Replacement	49
9.12	Console Replacement.....	51
9.13	Emergency Stop Switch Replacement	52
9.14	Console Frame Replacement.....	54
9.15	Heart Rate Board Service	55
9.16	Speed and Incline Keypad Replacement.....	56
9.17	Handlebar Frame Replacement	57
9.18	Heart Rate Handlebar Replacement	58
9.19	Heart Rate Grips Replacement.....	59
9.20	Console Mast Replacement.....	60
9.21	Testing the Treadmill	61

CHAPTER 10: TREADMILL SPECIFICATIONS AND ASSEMBLY GUIDE

10.1	Treadmill Specifications	62
10.2	Fasteners and Assembly Tools	63
10.3	Assembly Instructions	64
10.4	TV Bracket Installation	68

CHAPTER 11: SOFTWARE UPGRADE GUIDE

11.1	Software Upgrade Instructions.....	71
------	------------------------------------	----

1.1 SERIAL NUMBER LOCATION

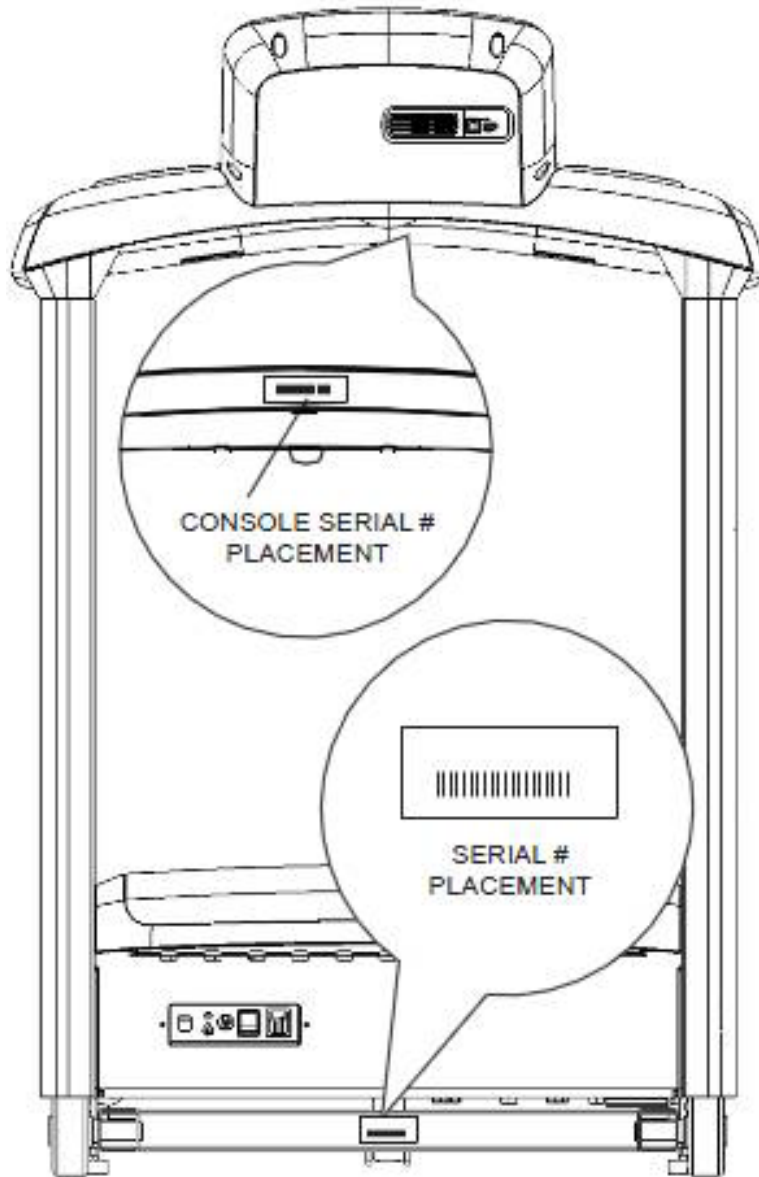

CHAPTER 2: IMPORTANT SAFETY INSTRUCTIONS

2.1 BEFORE GETTING STARTED

This treadmill is intended for commercial use. To ensure your safety and protect the equipment, read all instructions before operating the Matrix Treadmill.

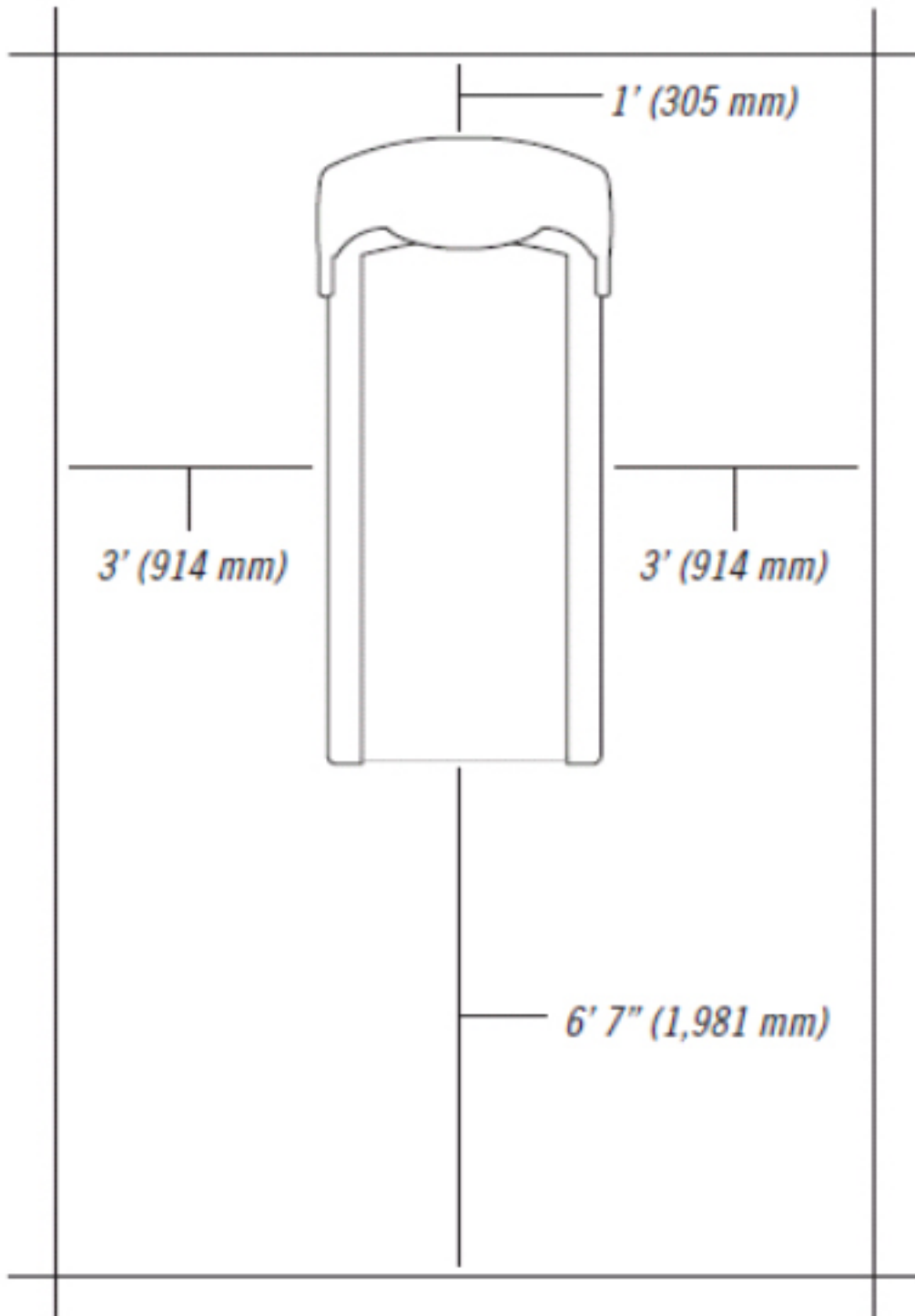

Please leave a 78.75" (2000 mm) x 39.50" (1000 mm) landing zone behind the treadmill. This zone is to allow easy access to the treadmill and gives the user an easy exit path from the machine. In case of an emergency, place both hands on the side arm rests to hold yourself up and place your feet onto the side rails.

2.2 READ AND SAVE THESE INSTRUCTIONS

This treadmill is intended for commercial use. To ensure your safety and protect the equipment, read all instructions before operating the MATRIX T1x-03 treadmill. When using an electrical product, basic precautions should always be followed including the following:

DANGER: To reduce the risk of electric shock: Always unplug this equipment from the electrical outlet immediately after using and before cleaning.

WARNING: To reduce the risk of burns, fire, electrical shock or injury to persons that may be associated with using this product.

An appliance should never be left unattended when plugged in. Unplug from the outlet when not in use and before putting on or taking off parts.

This product must be used for its intended purpose described in this service manual. Do not use other attachments that are not recommended by the manufacturer. Attachments may cause injury.

To prevent electrical shock, never drop or insert any object into any opening.

Do not remove the console covers. Service should only be done by an authorized service technician.

Never operate the treadmill with the air opening blocked. Keep the air opening clear, free of lint and hair.

Never operate product if it has a damaged cord or plug, if it is working improperly, if it has been damaged, or immersed in water.

Do not carry this unit by its supply cord or use the cord as a handle.

Keep any power cord away from heated surfaces.

Close supervision is necessary when the treadmill is used by or near children or disabled persons.

Do not use outdoors.

Do not operate where aerosol (spray) products are being used or when oxygen is being administered.

To disconnect, turn all controls to the off position, then remove plug from the outlet.

Connect this treadmill to properly grounded outlets only.

CAUTION: If you experience chest pain, nausea, dizziness or shortness of breath, STOP exercising immediately and consult a physician before continuing.

- Do not use the equipment in any way other than designed or intended by the manufacturer. It is imperative that all Matrix Fitness System's equipment is used properly to avoid injury.
- Keep hands and feet clear of moving parts at all times to avoid injury.
- Unsupervised children must be kept away from this equipment.
- Do not wear loose clothing while on equipment.

CHAPTER 2: IMPORTANT SAFETY INSTRUCTIONS

2.3 ELECTRICAL REQUIREMENTS

For your safety and to ensure good treadmill performance, the ground on this circuit must be non-looped. Please refer to NEC articles 210-21 and 210-23. Your treadmill is provided with a power cord with a plug listed below and requires the listed outlet. Any alterations of this power cord could void all warranties of this product..

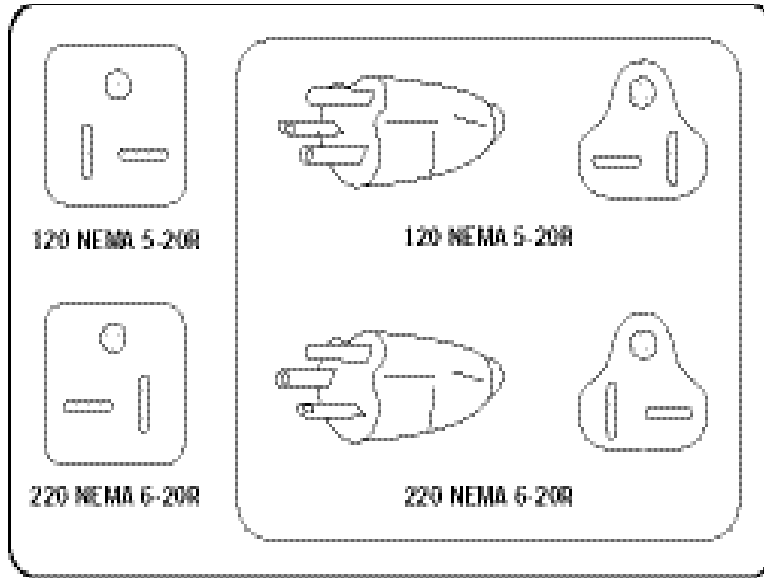

MATRIX DEDICATED CIRCUIT / ELECTRICAL REQUIREMENT INFO

All Matrix treadmills require the use of a 20 amp "dedicated circuit" with a non-looped (isolated) neutral / ground for the power requirement. Quite simply this means that each outlet you plug your treadmill into should not have anything else running on that same circuit. The easiest way to verify this is to locate the main circuit breaker box, and turn off the breaker(s) one at a time. Once a breaker has been turned off, the only thing that should not have power to it is the treadmill. No lamps, vending machines, fans, sound systems, or any other item should lose power when you perform this test.

Non-looped (isolated) neutral / grounding means that each circuit must have an individual neutral / ground connection coming from it, and terminating at an approved earth ground. You cannot "jumper" a single neutral / ground from one circuit to the next.

In addition to the dedicated circuit requirement, the proper gauge wire must be used from the circuit breaker box, to each outlet that will have the maximum number of units running off of it. If the distance from the circuit breaker box, to each outlet, is 100 feet or less, then 12 gauge wire may be used. For any distance greater than 100 feet from the circuit breaker box to the outlet, 10 gauge wire must be used.

TV POWER REQUIREMENTS

If a TV will be added to the treadmill via a bracket, separate power must be provided for the TV. Matrix MYE TVs require the use of a 15 amp or 20 amp "dedicated circuit," with a non-looped (isolated) neutral/ground, for the power requirement. Up to 3 TVs can be daisy chained per 15 amp circuit or 4 per 20 amp circuit via a Matrix provided daisy chain.

3.1 RECOMMENDED CLEANING TIPS

Preventative maintenance and daily cleaning will prolong the life and look of your MATRIX T1x-03 Treadmill.

Please read and follow these tips.

- Position the equipment away from direct sunlight. The intense UV light can cause discoloration on plastics.
- Locate your equipment in an area with cool temperatures and low humidity.
- Clean with a soft 100% cotton cloth.
- Clean with soap and water or other non-ammonia based all purpose cleaners.
- Wipe foot rails, console, heart rate grips, and handlebars clean after each use.
- Do not pour liquids directly onto your equipment. This can cause damage to the equipment and in some cases electrocution.
- Check the running belt for proper tension and routing.
- Adjust the leveling feet when equipment wobbles or rocks.
- Maintain a clean area around the equipment, free from dust and dirt.

3.2 CHECK FOR DAMAGED PARTS

DO NOT use any equipment that is damaged or has worn or broken parts. Use only replacement parts supplied by Matrix Fitness Systems.

MAINTAIN LABELS AND NAMEPLATES. Do not remove labels for any reason. They contain important information. If unreadable or missing, contact Matrix Fitness Systems for a replacement at 866-693-4863 or www.matrixfitness.com.

MAINTAIN ALL EQUIPMENT. Preventative maintenance is the key to smoothly operating equipment. Equipment needs to be inspected at regular intervals. Defective components must be kept out of use until they are repaired. Ensure that any person(s) making adjustments or performing maintenance or repair of any kind is qualified to do so. Matrix Fitness Systems will provide service and maintenance training at our corporate facility upon request or in the field if proper arrangements are made.

CHAPTER 3: PREVENTATIVE MAINTENANCE

3.3 CARE AND MAINTENANCE INSTRUCTIONS

In order to maximize life span, and minimize down time, all Matrix Fitness System's equipment requires regular cleaning, and maintenance items performed on a scheduled basis. This section contains detailed instructions on how to perform these items and the frequency of which they should be done. Some basic tools and supplies will be necessary to perform these tasks which include (but may not be limited to):

- * Metric Allen wrenches
- * #2 Phillips head screwdriver
- * Adjustable wrench
- * Torque wrench (capability to read foot lbs and inch lbs)
- * Lint free cleaning cloths
- * Teflon based spray lubricant such as "Super Lube" or other Matrix approved products.
- * Mild water soluble detergent such as "Simple Green" or other Matrix approved products
- * Vacuum cleaner with an extendable hose and crevasse tool attachment.

You may periodically see addendums to this document, as the Matrix Technical Support Team identifies items that require specific attention, the latest version will always be available on the Matrix web site at www.matrixfitness.com.

DAILY MAINTENANCE ITEMS

- 1) Clean the entire machine using water and mild detergent such as "Simple Green", or other Matrix approved solutions (cleaning agents MUST be alcohol and ammonia free).
- 2) Check the emergency stop button and cord for proper operation.

MONTHLY MAINTENANCE ITEMS

- 1) Inspect the power cord for damage, inspect the hand grip areas, and inspect the emergency stop button and cord for proper operation.
- 2) Check the running belt for proper tension, adjust as needed.

QUARTERLY MAINTENANCE ITEMS

- 1) Remove the front plastic cover, and vacuum the entire inside area of machine. Be careful when working around the MCB not to bump any wires or connections loose.
- 2) Check the drive belt for visible wear, ie, cracking, tears, etc. The belt should be replaced if there are any visible signs of damage. Proper alignment of the pulley / tensioner should be verified at this time as well.
- 3) Remove the motor cover at the front of the machine. Start the unit and raise the incline settings to maximum height. Turn the power switch off at the front of the machine to prevent it from lowering accidentally. Lubricate the incline motor Acme screw (Matrix recommends Super Lube brand grease with PTFE additive).

BI-ANNUAL MAINTENANCE ITEMS

- 1) Remove any wax build up from the front and rear rollers of the machine.
- 2) Inspect the underside of the running belt for damage, check for cracking or glazed surfaces.
- 3) If the belt has damage or wear to it that warrants replacement, note that a new running belt should ALWAYS be installed on a new deck surface (deck should either be flipped or replaced to gain a new surface).
- 4) During normal operating conditions, the running belt replacement and deck service should be done every 15,000 miles.

3.4 AUTO CALIBRATION INSTRUCTIONS

Run Auto Calibration to calibrate incline after assembly and after replacing any electronic component.

AUTO CALIBRATION PROCEDURE:

- 1) Press and hold the INCLINE DOWN and SPEED DOWN keys for three seconds until Manager appears on the middle LED display.
- 2) Press the SPEED or INCLINE UP key until Engineering appears on the display.
- 3) Press ENTER once Engineering is displayed.
- 4) Scroll between programs in the Engineering Mode using any UP or DOWN key until Auto Calibration appears on the middle LED display.
- 5) Press ENTER once Auto Calibration is displayed., you should not be standing on the running belt.
- 6) After completion, the display will either return to normal operation (if the unit passed the Auto Calibration) or display that the Auto Calibration failed.

3.5 ADJUSTING THE RUNNING BELT

After placing the treadmill in the position it will be used, the belt must be checked for proper tension and centering. The belt may need to be adjusted after the first 2 hours of use. Temperature, humidity, and use cause the belt to stretch at different rates. If the belt starts to slip when a user is on it, be sure to follow the directions below.

STEP 1: Locate the two hex head bolts on the rear of the treadmill. The bolts are located at each end of the frame at the back of the treadmill. These bolts adjust the rear roller. Do not adjust until the treadmill is on. This will prevent over tightening of one side.

STEP 2: The belt should have equal distance on either side between the frame. If the belt is touching one side, do not start the treadmill. Turn the bolts counter clockwise approximately one full turn on each side. Manually center the belt by pushing the belt from side to side. Tighten the bolts the same amount as when the user loosened them, approximately one full turn. Inspect the belt for damage.

STEP 3: While the treadmill is running at 3 mph, observe the belt position. If it is moving to the right, tighten the right bolt by turning it clockwise 1/4 turn, and loosen the left bolt 1/4 turn. If it is moving to the left, tighten the left bolt by turning it clockwise 1/4 turn and loosen the right 1/4 turn. Repeat Step 3 until the belt remains centered for several minutes.

STEP 4: Check the tension of the belt. The belt should be very snug. When a person walks or runs on the belt, it should not hesitate or slip. If this occurs, tighten the belt by turning both bolts clockwise 1/4 turn. Repeat if necessary.

3.6 KNOWING WHEN TO REPLACE THE RUNNING BELT AND DECK

One of the most common wear and tear items on a treadmill is the deck and belt combination. If these two items are not properly maintained, they can cause damage to other components. Always keep your deck and belt free of dirt and dust by wiping the edges of the belt and deck and up to 2" under the belt with a clean dry cloth.

To tell if your deck and belt combination needs to be replaced:

- 1) Have someone between 150-200lbs run on the treadmill at about 3 MPH.
- 2) Use a multi - meter to measure the amp draw with the user running. During normal use, the amp draw should be close to 5 amps. If the amp draw is significantly higher than 5 amps, replace the belt and / or flip / replace the running deck.

4.1 T1X-03 CONSOLE DESCRIPTION



WORKOUT KEYS: Simple program view and selection buttons.

QUICK START / GO: One touch Start and Quick Start.

ENTER: To confirm each program setting.

UP / DOWN INCLINE: Easy information and incline selection.

UP / DOWN SPEED: Easy information and speed selection.

EMERGENCY STOP / IMMOBILIZATION: To stop all functions and immobilize the unit. The emergency stop on this treadmill must be returned to its original position in order to allow normal operation of the unit.

STOP: Ends workout and shows workout summary data.

PAUSE: Pauses workout. Pause duration can be set in Manager Mode.

COOL DOWN: Puts treadmill into Cool Down mode. Cool Down time is dependent on the length of the workout. Workouts 19 minutes and shorter will have a cool down length of 2 minutes. Workouts 20 minutes and longer will have a cool down length of 5 minutes.

CHANGE DISPLAY BUTTON: Allows the user to select the data feedback that is displayed.

4.2 MANUAL WORKOUT OPERATION

QUICK START OPERATION

Press the GO key and the treadmill will enter into a manual mode of operation. All energy expenditure values will be calculated using the default weight measurement.

MANUAL WORKOUT OPERATION

Manual is a workout that allows you to manually adjust the speed and incline values at anytime. The manual workout also contains a setup screen which allows you to input your weight to help calculate a more accurate caloric burn rate.

To enter into this Manual Workout:

- 1) Choose the Manual Workout by selecting the MANUAL WORKOUT button and press ENTER.
- 2) Enter the desired workout length using the INCLINE or SPEED KEYS and press ENTER.
- 3) Enter the user's weight (the user's weight is used to calculate the caloric expenditure value-providing an accurate weight helps to ensure an accurate caloric expenditure rating for each user) using the INCLINE or SPEED KEYS and press ENTER.
- 4) Enter the desired initial incline value using the INCLINE or SPEED KEYS and press ENTER.
- 5) Enter the desired start speed using the INCLINE or SPEED KEYS and press ENTER.
- 6) Press GO to begin the workout. The display will read 3, 2, 1, and then the workout will begin.

4.3 LEVEL BASED WORKOUT OPERATION

Your Matrix T1x-03 Treadmill offers a variety of level-based workouts to challenge users of all fitness levels. The following information will briefly explain the workouts and how to program the treadmill for each workout selection.

ROLLING HILLS WORKOUT OPERATION

Rolling Hills is a level based workout that automatically adjusts the incline value to simulate walking or running up hills.

- 1) Choose the Rolling Hills workout by selecting the ROLLING HILLS workout button and press ENTER.
- 2) Enter the desired intensity using the INCLINE or SPEED KEYS and press ENTER.
- 3) Enter the desired workout length using the INCLINE or SPEED KEYS and press ENTER.
- 4) Enter the user's weight (the user's weight is used to calculate the caloric expenditure value, providing an accurate weight helps to ensure an accurate caloric expenditure rating for each user) using the INCLINE or SPEED KEYS and press ENTER.
- 5) Press GO to begin the workout. The display will read 3, 2, 1, and then the workout will begin.

FAT BURN WORKOUT OPERATION

Fat Burn is a level-based workout that is designed to help users burn fat through various incline changes.

- 1) Choose the Fat Burn workout by selecting the FAT BURN workout button and press ENTER.
- 2) Enter the desired intensity level using the INCLINE or SPEED KEYS and press ENTER.
- 3) Enter the desired workout length using the INCLINE or SPEED KEYS and press ENTER.
- 4) Enter the user's weight (the user's weight is used to calculate the caloric expenditure value, providing an accurate weight helps to ensure an accurate caloric expenditure rating for each user) using the INCLINE or SPEED KEYS and press ENTER.
- 5) Press GO to begin the workout. The display will read 3, 2, 1, and then the workout will begin.

5K RUN WORKOUT OPERATION

5K Run is a level-based workout with a fixed distance of 5 kilometers. Incline is adjusted automatically throughout the workout. You control the speed.

- 1) Choose the 5K Run workout by selecting the 5K RUN workout button and press ENTER.
- 2) Enter the desired intensity level using the INCLINE or SPEED KEYS and press ENTER.
- 3) Enter the user's weight (the user's weight is used to calculate the caloric expenditure value, providing an accurate weight helps to ensure an accurate caloric expenditure rating for each user) using the INCLINE or SPEED KEYS and press ENTER.
- 4) Press GO to begin the workout. The display will read 3, 2, 1, and then the workout will begin.

4.4 HEART RATE CONTROL WORKOUT OPERATION

Your Matrix T1x-03 Treadmill offers a heart rate control workout mode. The heart rate control workout mode allows the user to program their desired heart rate zone and maximum allowable incline and the treadmill will automatically adjust the incline based upon the user's heart rate. The heart rate zone is calculated using the following equation: $(220 - \text{Age}) \times \% = \text{target heart rate zone}$. The user must wear a telemetric heart rate monitor or continually hold onto the contact heart rate grips for his workout.

- 1) Choose the Target Heart Rate workout by selecting the HEART RATE workout button and press ENTER.
- 2) Enter the user's age using the INCLINE or SPEED KEYS and press ENTER.
- 3) Enter the desired percent of maximum heart rate using the INCLINE or SPEED KEYS and press ENTER.
- 4) Enter the user's weight (the user's weight is used to calculate the caloric expenditure value, providing an accurate weight helps to ensure an accurate caloric expenditure rating for each user) using the INCLINE or SPEED KEYS and press ENTER.
- 5) Press GO to begin the workout. The display will read 3, 2, 1, and then the workout will begin.



4.5 GERKIN TEST WORKOUT OPERATION

Your Matrix T1x-03 Treadmill offers a Gerkin Firefighter Protocol Fitness Test. The Gerkin Protocol was developed by Dr. Richard Gerkin of the Phoenix (Arizona) Fire Department. It is a sub-maximal graded treadmill evaluation used by many fire departments across the United States to assess the physical condition of the firefighters. The test requires constant monitoring of the user's heart rate so the use of a telemetric chest strap is highly encouraged. The workout operates as follows:

WARM UP: The warm up is 3 minutes long and runs at 3.0 mph (4.8 kph) and 0% incline.

STAGE 1: At the 3 minute mark, the treadmill will gradually increase speed to 4.5 mph (7.2 kph). The actual test begins at 4.5 mph (7.2 kph).

STAGE 2: After one minute, the treadmill incline will increase to 2%.

STAGE 3: After one minute, the treadmill speed increases to 5.0 mph (8.0 kph).

STAGES 4 THROUGH 11: After every odd minute the treadmill incline will increase by 2%. After every even minute the treadmill speed will increase by 0.5 mph (0.8 kph). Once the user's heart rate exceeds the target heart rate (85% of maximum as determined by the equation $(220 - \text{Age}) \times \% = \text{target heart rate zone}$), the individual continues the evaluation for an additional 15 seconds. During the 15 second period, the evaluation remains at the stage where the target heart rate is exceeded, without any change to speed or incline. If the heart rate does not return to or below the target heart rate, the evaluation ends and the final evaluation stage is recorded. If the heart rate returns to or below the target heart rate, the program continues at the point where it would have been had the program not stabilized for 15 seconds.

TEST COMPLETION: The test is completed when user's heart rate exceeds the target for more than 15 seconds or when the user completes all 11 stages, whichever occurs first. The treadmill will enter a cool down cycle for 3 minutes at 3.0 mph (4.8 kph), 0% incline.

- 1) Choose the Gerkin Test by pressing the FITNESS TEST workout button and press ENTER.
- 2) Enter the user's age using the INCLINE or SPEED KEYS and press ENTER.
- 3) The message window will display your target heart rate based upon your age and the target heart rate zone of 85%.
- 4) Select the user's gender using the INCLINE or SPEED KEYS and press ENTER.
- 5) Enter the user's weight (the user's weight is used to calculate the caloric expenditure value, providing an accurate weight helps to ensure an accurate caloric expenditure rating for each user) using the INCLINE or SPEED KEYS and press ENTER.
- 6) The message window will notify the user that the start speed is 3.0 mph (4.8 kph) and 0% incline during the warm-up.
- 7) Press GO to begin the workout. The display will read 3, 2, 1, and the workout will begin.

CHAPTER 4: CONSOLE OVERLAY AND WORKOUT DESCRIPTION

4.5 GERKIN TEST WORKOUT OPERATION - CONTINUED

SUB MAXIMAL TREADMILL EVALUATION CONVERSION TABLE

Stage	Time	Converted VO2max
1	1:00	31.15
2.1	1:15	32.55
2.2	1:30	33.6
2.3	1:45	34.65
2.4	2:00	35.35
3.1	2:15	37.45
3.2	2:30	39.55
3.3	2:45	41.3
3.4	3:00	43.4
4.1	3:15	44.1
4.2	3:30	45.15
4.3	3:45	46.2
4.4	4:00	47.5
5.1	4:15	48.6
5.2	4:30	50
5.3	4:45	51.4
5.4	5:00	52.8
6.1	5:15	53.9
6.2	5:30	54.9
6.3	5:45	56
6.4	6:00	57
7.1	6:15	57.7
7.2	6:30	58.8
7.3	6:45	60.2
7.4	7:00	61.2
8.1	7:15	62.3
8.2	7:30	63.3
8.3	7:45	64
8.4	8:00	65
9.1	8:15	66.5
9.2	8:30	68.2
9.3	8:45	69
9.4	9:00	70.7
10.1	9:15	72.1
10.2	9:30	73.1
10.3	9:45	73.8
10.4	10:00	74.9
11.1	10:15	76.3
11.2	10:30	77.7
11.3	10:45	79.1
11.4	11:00	80

CARDIOVASCULAR FITNESS PERCENTILES

Males:	VO2 max (ml/kg/min)			
	0-29	30-39	40-49	50-59
SUPERIOR	>58.8	>58.9	>55.4	>52.5
	54.0	52.5	50.4	47.1
EXCEL- LENT	51.4	50.3	48.2	45.3
	48.2	46.8	44.1	41.0
GOOD	46.8	44.6	41.8	38.5
	44.2	42.4	39.9	36.7
FAIR	42.5	41.0	38.1	35.2
	41.0	38.9	36.7	33.8
POOR	39.5	37.4	35.1	32.3
	37.1	35.4	33.0	30.2
VERY POOR	34.5	32.5	30.9	28.0
	31.6	30.9	28.3	25.1

Females:	VO2 max (ml/kg/min)			
	20-29	30-39	40-49	50-59
SUPERIOR	>53.0	>48.7	>46.8	>42.0
	46.8	43.9	41.0	36.8
EXCEL- LENT	44.2	41.0	39.5	35.2
	41.0	38.6	36.3	32.3
GOOD	38.1	36.7	33.8	30.9
	36.7	34.6	32.3	29.4
FAIR	35.2	33.8	30.9	28.2
	33.8	32.3	29.5	26.9
POOR	32.3	30.5	28.3	25.5
	30.6	28.7	26.5	24.3
VERY POOR	28.3	26.5	25.1	22.3
	25.9	25.1	23.5	21.1

5.1 USING MANAGER MODE

- 1) To enter Manager Mode, press & hold INCLINE DOWN and SPEED DOWN keys at the same time for 3-5 seconds until Manager appears on the display.
- 2) To enter the Manager Mode, press ENTER once Manager appears on the display (Figure A).
- 3) To scroll between settings in the Manager Mode, press the INCLINE or SPEED keys.
- 4) Press ENTER to modify the settings once displayed.
- 5) Press any INCLINE or SPEED key to change the value of the setting.
- 6) Once the setting is correct, press ENTER to save.
- 7) Press the EMERGENCY STOP to exit Manager Mode..



FIGURE A

5.2 MANAGER MODE OVERVIEW

CUSTOM SETTINGS	DEFAULT	MINIMUM	MAXIMUM	UNIT	DESCRIPTION
MAXIMUM TIME	60	5	99	MINUTE	Maximum workout duration.
DEFAULT TIME	60	5	99 (limited to max time setting)	MINUTE	Default start time in all programs.
DEFAULT LEVEL	1	1	10	LEVEL	Default start level in all programs.
DEFAULT AGE	30	15	100	AGE	Default age used in HR programs.
DEFAULT WEIGHT	150 LB / 68 KG	50 LB / 23 KG	400 LB / 182 KG	POUND / KILOGRAM	Default weight used in calorie calculations and HR programs.
ACCUMULATED DISTANCE	N/A	N/A	65,000 MILES / 104,000 KM	MILE / KILOMETER	Total distance on treadmill, not editable. TO RESET: Press and hold INCLINE DOWN and SPEED DOWN for 3-5 seconds.
ACCUMULATED TIME	N/A	N/A	65,000 HOURS	HOUR	Total time on treadmill, not editable. TO RESET: Press and hold INCLINE DOWN and SPEED DOWN for 3-5 seconds.
SOFTWARE	N/A	N/A	N/A	N/A	Software Version, not editable.
START SPEED	0.5 MPH / 0.8 KPH	0.5 MPH / 0.8 KPH	2.0 MPH / 3.2 KPH	MPH / KPH	Controls the starting speed for all programs (does not affect minimum speeds).
MAXIMUM SPEED	12 MPH / 20 KPH	2.0 MPH / 3.2 KPH	12 MPH / 20 KPH	MPH / KPH	Controls the maximum speed for all programs.
TIMER MODE	DOWN	DOWN	UP	N/A	Controls whether the user time counts up or down.
SPEED MODE	MILE	MILE	KILOMETER	N/A	Measurement unit used for calorie calculations, distance, and speed.
OUT OF ORDER	OFF	ON	OFF	N/A	Locks the machine.
GENDER	MALE	MALE	FEMALE	N/A	Sets the user's gender.
LANGUAGE	ENGLISH	N/A	N/A	N/A	Sets the language shown on the console.
SOUND MODE	ON	ON	OFF	N/A	Controls whether the display broadcasts chime when buttons are pressed.
BELT STOP	OFF	OFF	30, 60, OR 90	SECONDS	This option checks for a user on the running belt. If there is no user detected, the unit will go into pause mode, and reset if no user for 5 minutes.

CHAPTER 6: ENGINEERING MODE

6.1 USING ENGINEERING MODE

- 1) To enter Engineering Mode, press & hold the INCLINE DOWN and SPEED DOWN keys at the same time for 3-5 seconds until Manager appears on the display.
- 2) Press the INCLINE or SPEED keys until Engineering appears on the display (Figure A) and press ENTER.
- 3) To scroll between settings in the Engineering Mode, press the INCLINE or SPEED keys.
- 4) Press ENTER to modify the settings once displayed.
- 5) Press any INCLINE or SPEED key to change the value of the setting.
- 6) Once the setting is correct, press ENTER to save.
- 7) Press the EMERGENCY STOP to exit Engineering Mode..



FIGURE A

6.2 ENGINEERING MODE OVERVIEW

CUSTOM SETTING	DEFAULT	MINIMUM	MAXIMUM	UNIT	DESCRIPTION
Disable Errors	OFF	OFF	ON	N/A	Off - Shows A-C class errors. On - Shows C class errors only.
Elevation Minimum	28	20	239	N/A	Controls the low incline parameter.
Elevation Maximum	230	20	239	N/A	Controls the high incline parameter.
Auto Calibration	N/A	N/A	N/A	N/A	This function is to calibrate the treadmill incline.
Speed Units	MILE	MILE	KILOMETER	DISTANCE	Measurement unit used for calorie calculations, distance, and speed.
Pause Time	30 SECONDS	5 SECONDS	10 MINUTES	SECOND / MINUTE	Controls the maximum time the treadmill can be paused during a workout.
Serial Number	N/A	N/A	N/A	N/A	Serial Number input is available for both the Console and Frame. Due to the limited LED characters, 2 layers are used to enter the serial number. First Layer: - P P P P P V - P P P P P is the product name - V is the version. If the version is A, just leave this blank. Second Layer - Y Y M M n n n n n. - Y Y is the year (11, 12). - M M is the month (e.g. 08, 09, 10). - n n n n n is the actual serial number. Use the UP / DOWN LEVEL keys to navigate the layers and the number keys to input the serial number. The product name is dependent on the Machine Type setting. For example, the console is TM507 with ver. C and the manufactured date is 2011.08 with 98765. The frame is TM507 with ver. C and the manufactured date is 2011.06 with 12345. Their serial numbers are: Console SN: TM507C 1st layer, 110898765 2nd layer. Frame SN: TM507C 1st layer, 110612345 2nd layer.
Reset Defaults	N/A	N/A	N/A	N/A	Reset the default values to factory settings.
Club ID	N/A	N/A	N/A	N/A	This sets the club ID for clubs using Asset Management.

7.1 USING SERVICE MODE

- 1) To enter Service Mode, press & hold the INCLINE DOWN and SPEED DOWN keys at the same time for 3-5 seconds until Manager appears on the display.
- 2) Press the INCLINE or SPEED keys until Service appears on the display (Figure A) and press ENTER.
- 3) To scroll between settings in the Service Mode, press the INCLINE or SPEED keys.
- 4) Press ENTER to modify the settings once displayed.
- 5) Press any INCLINE or SPEED key to change the value of the setting.
- 6) Once the setting is correct, press ENTER to save.
- 7) Press the EMERGENCY STOP to exit Service Mode..

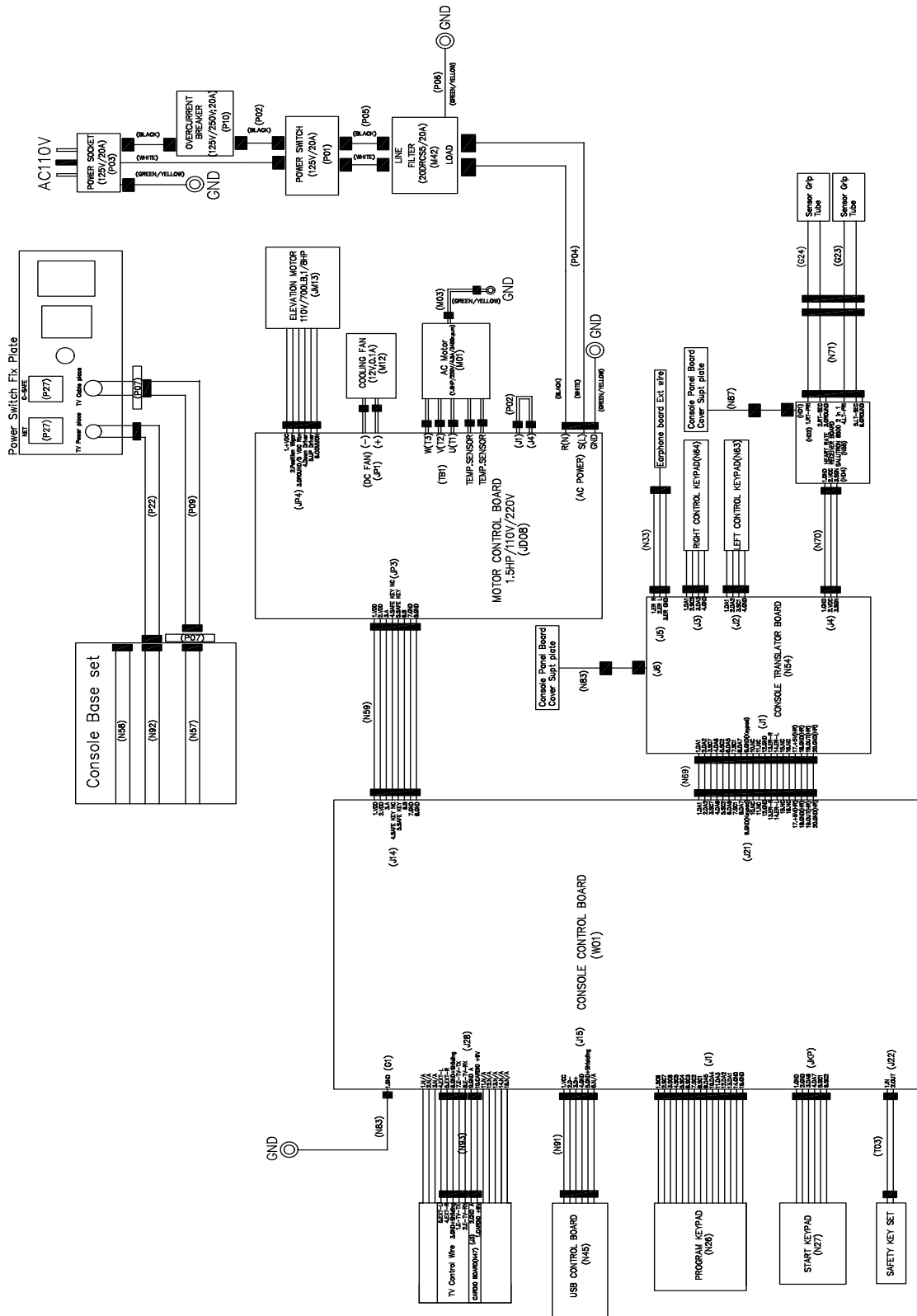

FIGURE A

7.2 SERVICE MODE OVERVIEW

CODE	DEFAULT	OPTIONS	DESCRIPTION
Service 1	Display Test		Press the ENTER key repeatedly to check each set of LEDs on the display sequentially.
Service 2	Keypad Test		Press any key and the display should show the corresponding message.
Service 3	Distance / Time	Distance: Mile 0 - 99999 Kilometer 0 - 160898 Time: 0 - 999999	Manually sets the Accumulated Distance and Time.
Service 4	Error Log		Shows the last 10 errors. Press and LEVEL UP and DOWN for 3 seconds to clear the errors.
Service 5	Set Date / Time		Press the LEVEL keys to move cursor, the number keys to set date / time, and the ENTER key to save.

8.1 ELECTRICAL DIAGRAMS



CHAPTER 8: TROUBLESHOOTING

8.1 ELECTRICAL DIAGRAMS - CONTINUED

DIGITAL COMMUNICATION WIRE - N59

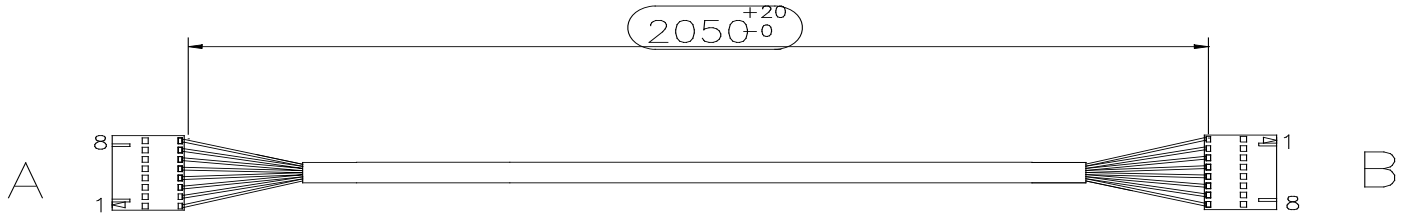

A.HOLE	B.HOLE	FUNCTION	COLOR
1	1	12V	red
2	2	12V	
3	3	RDA	
4	4	SAFE KEY	
5	5	SAFE KEY	
6	6	RDB	
7	7	GND	black
8	8	GND	

PULSE GRIP WIRE - N71

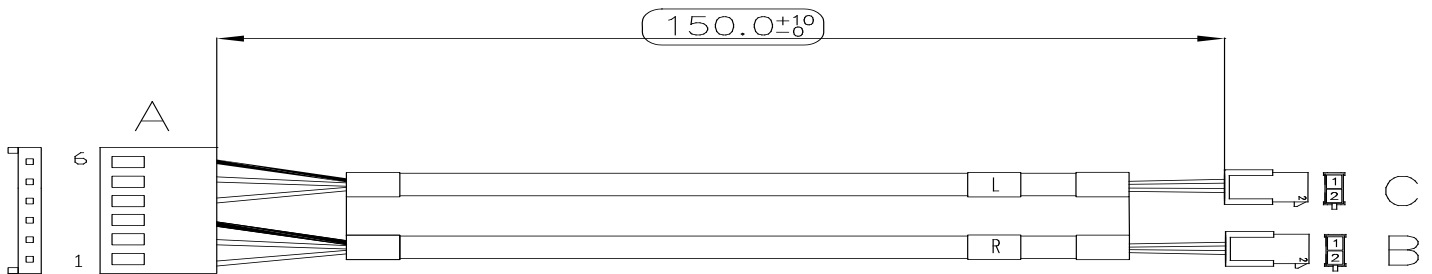

A: HOLE	B: HOLE	C: HOLE	FUNCTION	COLOR
1	1		RT-PRI	RED
2	2		RT-SEC	WHITE
3			GROUND	Shielding
4		1	LT-PRI	RED
5		2	LT-SEC	WHITE
6			GROUND	Shielding

8.1 ELECTRICAL DIAGRAMS - CONTINUED

PULSE GRIP CONNECTING WIRE - N70

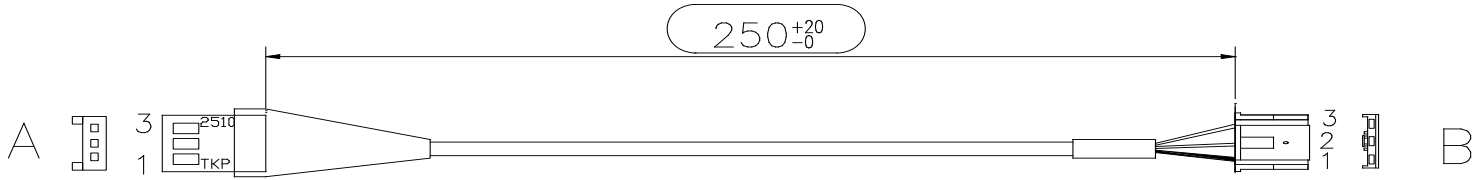

A.HOLE	B.HOLE	COLOR	FUNCTION
1	1	black	A:GND and noShield B: GND+Shield
2	2	red	VCC
3	3		SGN

8.2 MCB WIRING

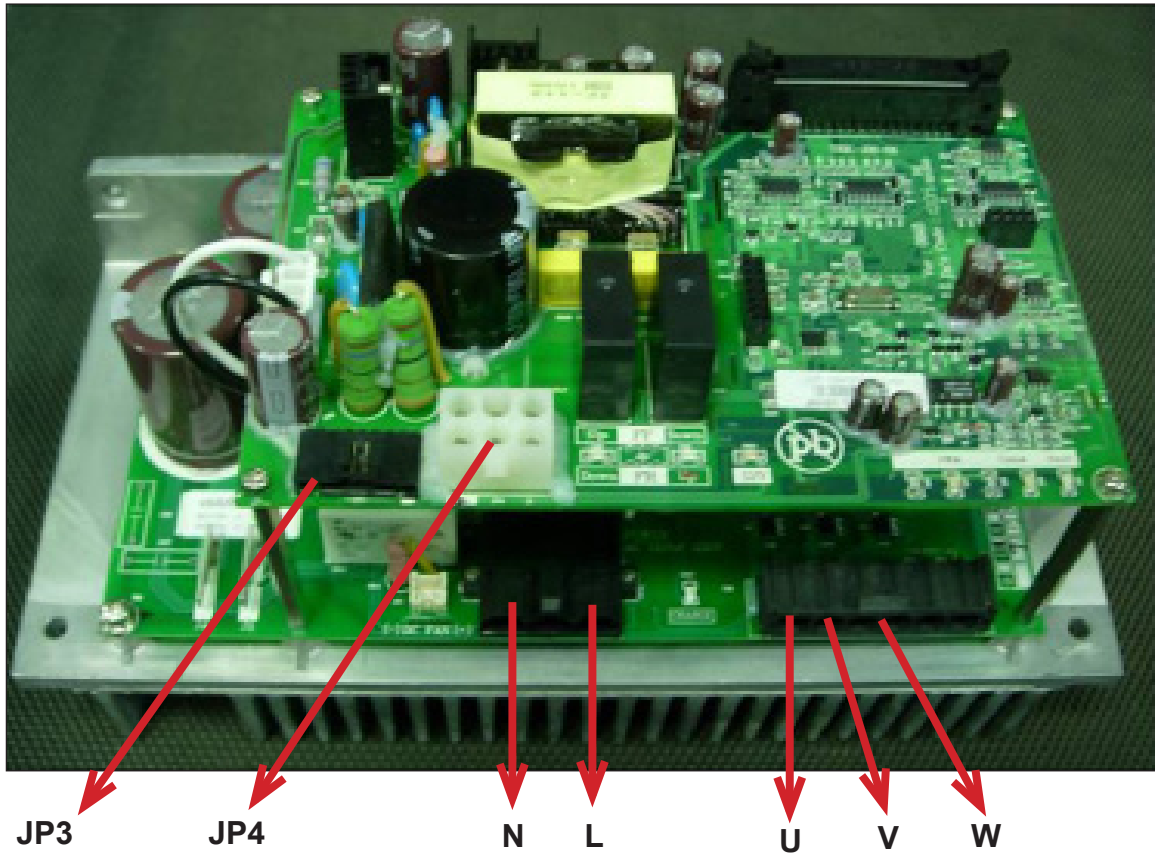

- JP3 - Console Cable
- JP4 - Incline Motor Cable
- N - Power Input (white)
- L - Power Input (Black)
- U - Motor Wire (red)
- V - Motor Wire (White)
- W - Motor Wire (Black)

8.3 MCB LED PLACEMENT AND DEFINITIONS

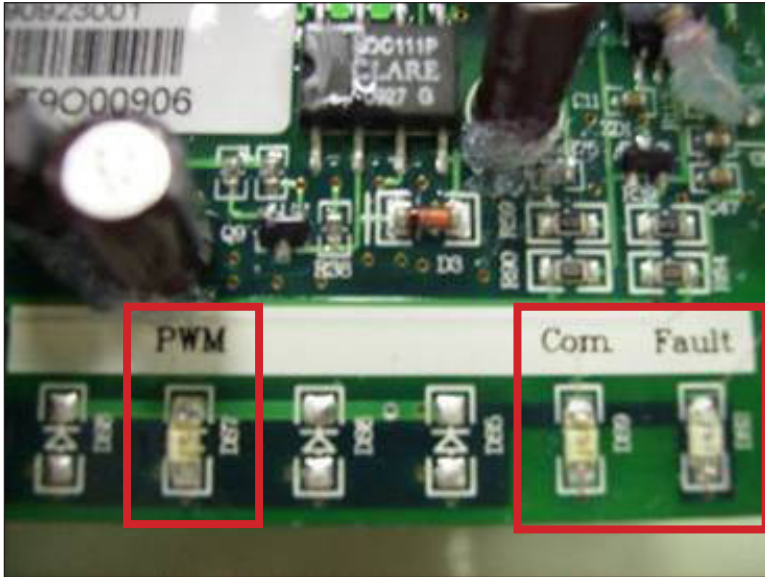

PWM - Console PWM signal light (when the motor is running, the light should flash).

COM - Digital communication light.

FAULT - The machine has stopped due to any C class error.

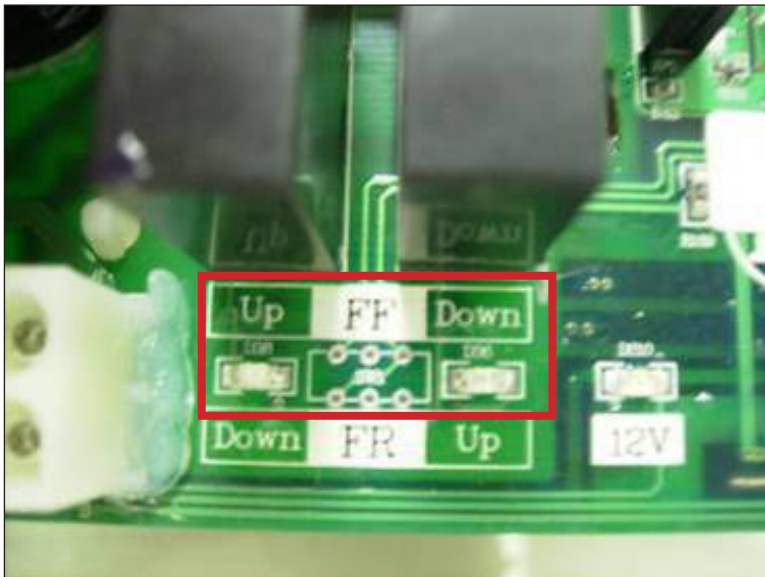

UP / DOWN (FF) - Incline motor status light.

CHAPTER 8: TROUBLESHOOTING

8.4 ERROR MESSAGES ON THE CONSOLE

CLASS LEVEL	ERROR CODE	DESCRIPTION	CONDITION
B	0140	Incline motor fail.	When the incline motor is supposed to move, it does not move. When the error happens the incline motor will be locked. The command "initialize" is needed to unlock the incline.
C	01A0	Incline motor disconnection.	When the incline position cable is not connected.
C	01A4	Main motor U phase disconnection.	Main motor U phase disconnection.
C	01A5	Main motor V phase disconnection.	Main motor V phase disconnection.
C	01A6	Main motor W phase disconnection.	Main motor W phase disconnection.
C	01A8	Main motor over current.	Main motor over current of 7 amps.
C	01AB	Inverter Error.	Internal error of the inverter.
C	01AD	Motor over temperature.	When a heavy user makes the motor over load over go over current.
C	02A0	Main motor failed.	The belt does not move when commanded.
C	02A1	Over AC power input voltage.	Power input voltage over range.
C	02A2	Over / low DC bus voltage.	Power input voltage over range.
C	02A8	Inverter circuit of motor drive failed.	Motor resistance closed.
C	02AD	LCB over temperature.	LCB over temperature.
C	02B5	Inverter senses that the normal rated current is over 150% for over 60 seconds.	Inverter sensor is reading the normal rated current is over 10.5 amps for 60 seconds.
C	02B6	Speed up has over current.	Software issue.
C	02B7	Speed down has over current.	Software Issue.
C	02B8	Running status over current.	Software Issue.
C	02B9	The inner memory IC data write error.	MCB failure.
C	02BA	The inner memory IC data read error.	MCB failure.
C	02BC	Ground connection or fuse error.	MCB failure.
C	02BD	Inverter hardware interrupt error.	MCB failure.
C	04A0	Digital communication failure. LCB has no return message from the UCB for 3 seconds.	Check the connection of the console cable at the UCB and MCB. Replace the console cable, UCB, or MCB as needed.
C	04B0	No UCB response.	Check the connection of the console cable at the UCB and MCB. Replace the console cable, UCB, or MCB as needed.

CLASS LEVEL

Class B - Will make a record in the error log. The machine will keep working.

Class C - The machine will stop and not work.

ERROR MESSAGE 0140 / 01A0

1) CAUSE:

- a. Incline motor operation failed.

2) SOLUTION:

- a. Check the connection of the incline motor cable at the MCB.
- b. Run auto calibration (See Section 3.5).
- c. If auto calibration fails, press GO and attempt to incline the treadmill.
 - Check the MCB UP and DOWN (FF) LEDs (Figure A). If the LEDs do not light up when incline is commanded, replace the console cable or console. If the LEDs do light up, replace the incline motor.
- d. If replacing the console, console cable, and incline motor do not resolve the issue, replace the MCB.

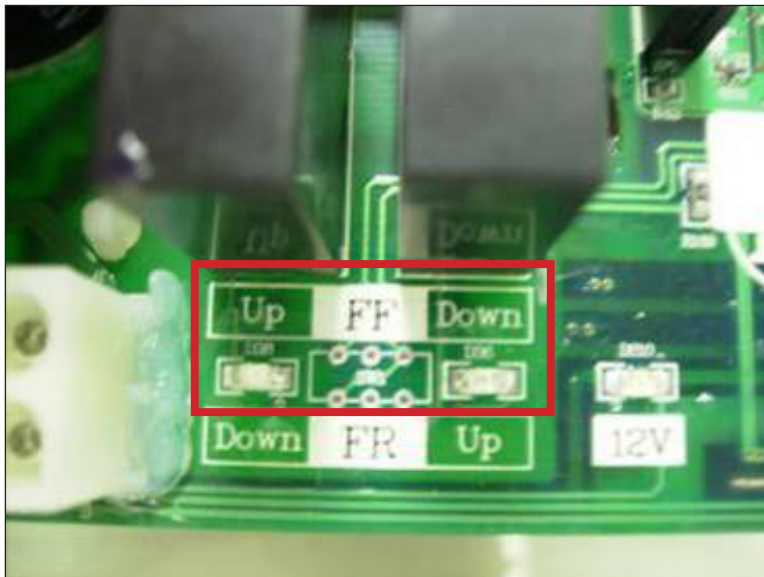

FIGURE A

8.6 01A4 / 01A5 / 01A6 ERROR TROUBLESHOOTING

ERROR MESSAGE 01A4 / 01A5 / 01A6

1) CAUSE:

- a. 01A4 - Main motor U phase disconnection.
- b. 01A5 - Main motor V phase disconnection.
- c. 01A6 - Main motor W phase disconnection.

2) SOLUTION:

- a. Check the connection of the motor cable at the MCB (Figure A).
- b. Replace the motor.
- c. Replace the MCB.

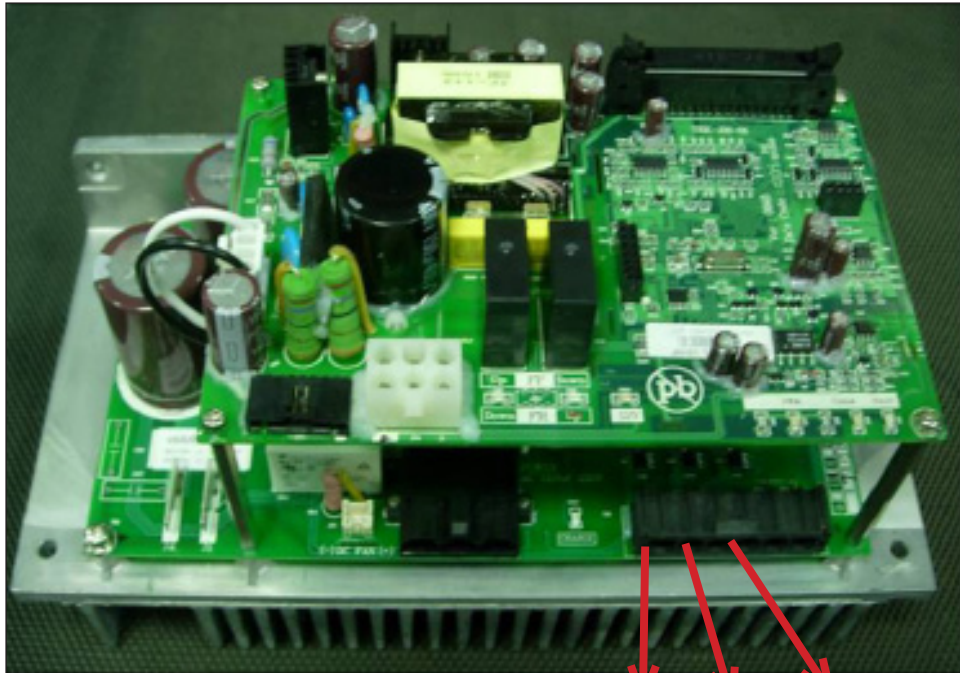

FIGURE A

U V W

8.7 01A8 / 01AD / 02B6 / 02B7 / 02B8 ERROR TROUBLESHOOTING

ERROR MESSAGE 01A8 / 01AD / 02B6 / 02B7 / 02B8

1) CAUSE:

- a. 01A8 - Main motor over current of 7 Amps.
- b. 01AD - Motor over temperature.
- c. 02B6 - Speed up is over current.
- d. 02B7 - Speed down is over current.
- e. 02B8 - Running status over current.

2) SOLUTION:

- a. See Section 3.6 for checking the status of the running deck and belt. Replace as needed.
- b. Replace the MCB.

8.8 01AB ERROR TROUBLESHOOTING

ERROR MESSAGE 01AB

1) CAUSE:

- a. Inverter error.

2) SOLUTION:

- a. When the display is showing an 01AB error, the MCB Fault LED should be lit (Figure A).
- b. If the MCB Fault LED is not lit, replace the console.
- c. If the MCB Fault LED is lit, replace the MCB.

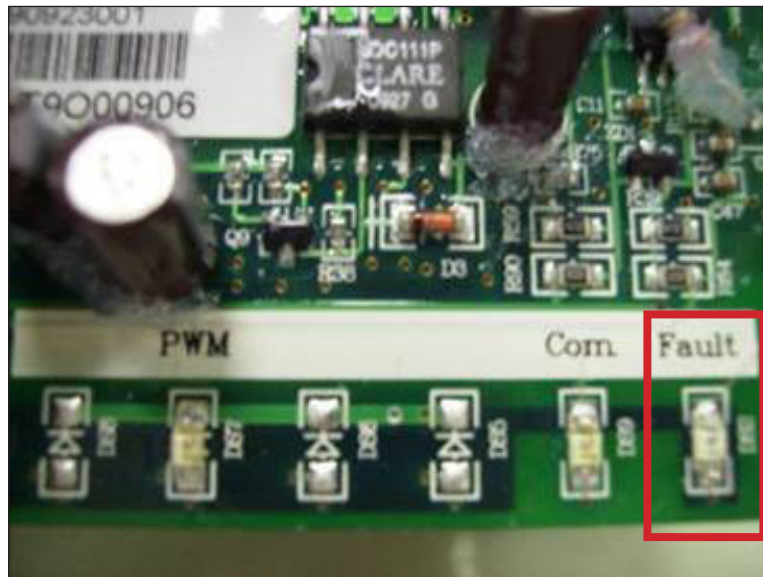

FIGURE A

ERROR MESSAGE 02A0 / 02A8

1) CAUSE:

- a. 02A0 - Main motor failure. The belt does not move when it is supposed to move.
- b. 02A8 - Inverter circuit of the motor failed. Motor resistance is closed.

2) SOLUTION:

- a. Check the connection of the motor cable at the MCB (Figure A).
- b. Use a multi - meter to check the motor cable for resistance at 3 points (Figures B, C, & D).
- c. If the motor cable displays an ohm value, replace the MCB.
- d. If the motor cable does not display an ohm value, replace the motor.

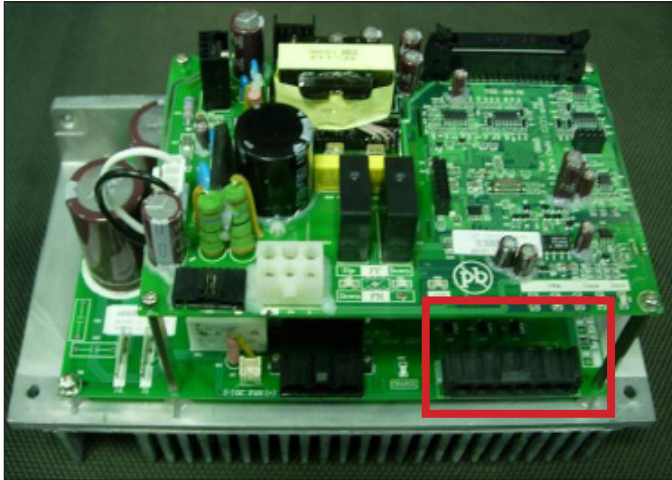

FIGURE A

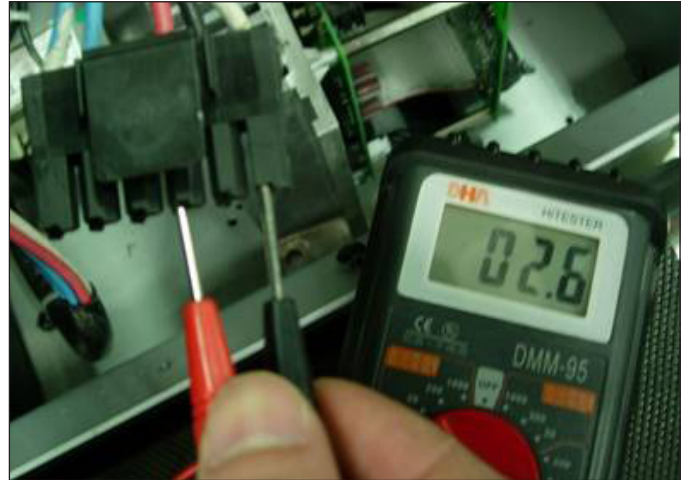

FIGURE B

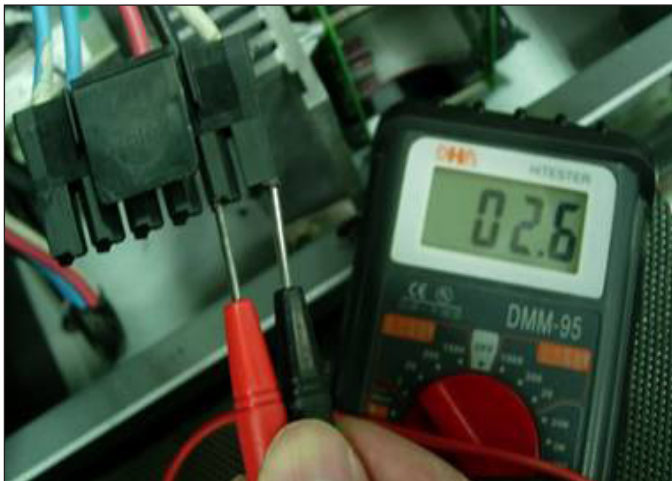

FIGURE C



FIGURE D

8.10 02A1 / 02A2 ERROR TROUBLESHOOTING

ERROR MESSAGE 02A1 / 02A2

1) CAUSE:

- a. 02A1 - Over AC power input voltage.
- b. 02A2 - Over / low DC bus voltage.

2) SOLUTION:

- a. Use a multi - meter to check if the input power is over 260V.
- b. If the power outlet is ok, replace the MCB.

8.11 02AD ERROR TROUBLESHOOTING

ERROR MESSAGE 02AD

1) CAUSE:

- a. MCB over temperature.

2) SOLUTION:

- a. Check the condition and connection of the motor cable at the MCB (Figure A).
- b. Use a multi - meter to check the motor cable for resistance at the 2 blue wires in the cable (Figure B).
- c. If the blue wires of the motor cable display an ohm value, replace the motor.
- d. If the blue wires of the motor cable do not display an ohm value, replace the MCB.

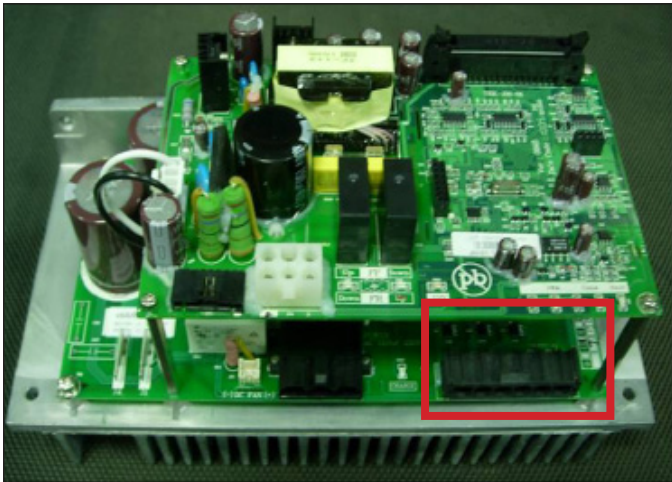

FIGURE A



FIGURE B

8.12 02B5 ERROR TROUBLESHOOTING

ERROR MESSAGE 02B5

1) CAUSE:

- a. The inverter sensor is reading the normal rated current is over 10.5 amps for 60 seconds.

2) SOLUTION:

- a. Use a multi - meter to check the motor cable for resistance at 3 points (Figures A, B, & C).
- b. If the motor cable displays an ohm value over 4, replace the motor.
- c. If the motor cable displays an ohm value under 4, replace the MCB.

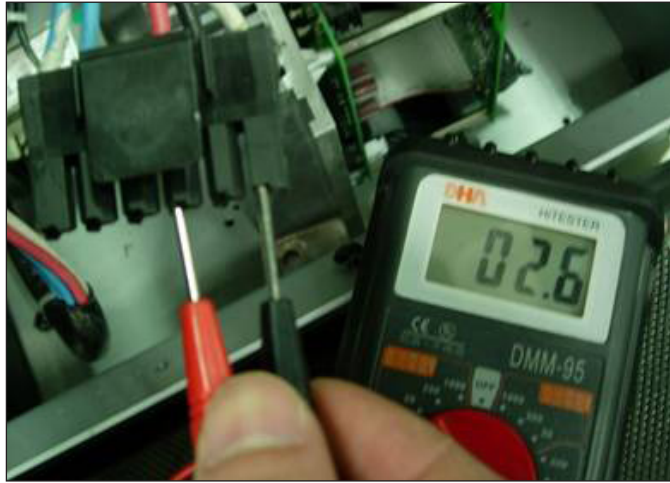

FIGURE A



FIGURE B

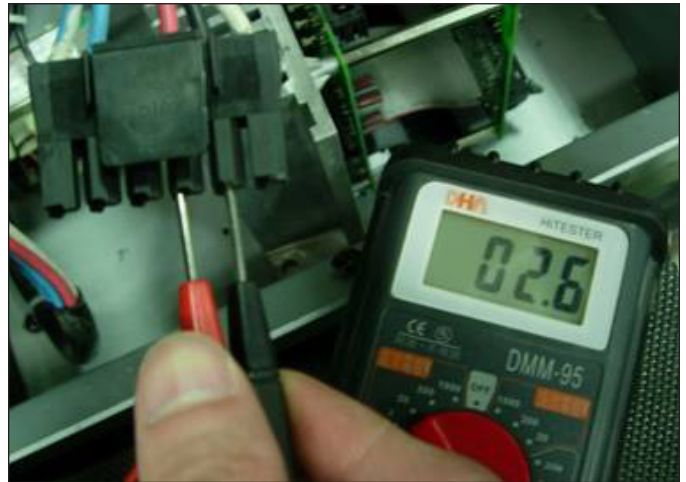

FIGURE C

ERROR MESSAGE 02B9 / 02BA / 02BC / 02BD

1) CAUSE:

- a. 02B9 - The inner memory IC data write error.
- b. 02BA - The inner memory IC data read error.
- c. 02BC - Ground connection or fuse error.
- d. 02BD - Inverter hardware interrupt error.

2) SOLUTION:

- a. Replace the MCB.

8.14 04A0 ERROR TROUBLESHOOTING

ERROR MESSAGE 04A0

1) CAUSE:

- a. No communication response.

2) SOLUTION:

- a. If an 04A0 error is displayed, MCB Com LED should not be lit (Figure A).
- b. Check the connection of the digital communication wire at the MCB (Figure B).
- c. Replace the digital communication wire.
- d. Replace the console.
- e. Replace the MCB.



FIGURE A

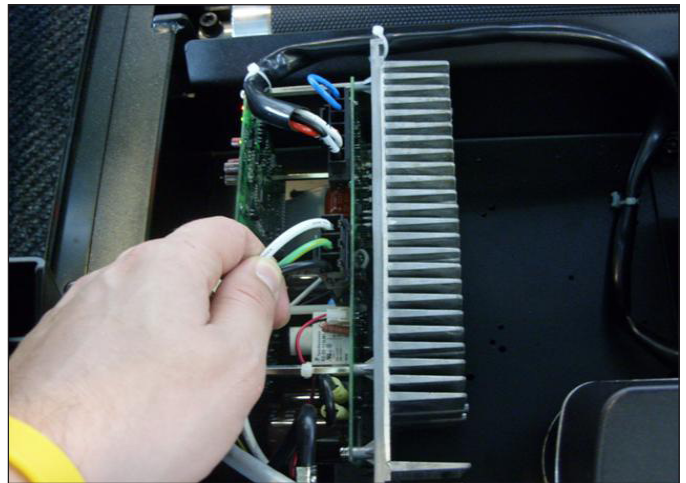

FIGURE B

HEART RATE FUNCTION DOES NOT WORK OR IS READING INCORRECTLY

POSSIBLE CAUSES:

- 1) The chest strap being used is not making good contact with the user's chest.
- 2) The chest strap is at a low battery status.
- 3) The chest strap is damaged.
- 4) The HR grips are damaged.
- 5) The HR board is damaged.
- 6) The UCB is damaged.

SOLUTION:

- 1) Re-center the chest strap below the user's pectoral muscle (Figure A) and check again.
- 2) Replace the battery in the chest strap.
- 3) Replace the chest strap.
- 4) If there is no HR present, replace the HR grips.
- 5) If there is a HR present but it is much higher than normal, replace the HR board.
- 6) If replacing the HR grips and board does not resolve the issues, replace the console.

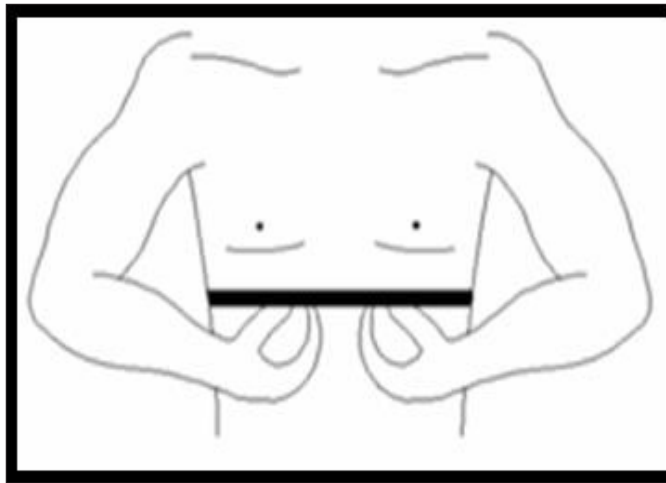

FIGURE A

CHAPTER 8: TROUBLESHOOTING

8.16 ENTERTAINMENT TROUBLESHOOTING - OVERVIEW

1. Sections 8.16 - 8.19 will help with diagnosing problems with TV and entertainment related equipment that is produced by Matrix Fitness Systems.
2. The T1x-03 treadmill has the capability of adding an external 15" TV with a bracket. A Matrix brand external TV will look similar to the TV in Figure A. Your control keypad should look similar to Figure B. If your equipment looks different contact Matrix or the manufacturer of your TV equipment if known.



FIGURE A



FIGURE B

3. Verify how your TV is mounted, compare your machine to Figure C which shows an external 15" TV directly mounted to a T1x Treadmill.



FIGURE C

4. For Matrix produced and mounted equipment you can use the information outlined in this section to help with any connection and power issues you may have. If you have questions that are specific to the TV alone (settings, programming, menu options, etc) please see the entertainment owner's manual.

CHAPTER 8: TROUBLESHOOTING

8.17 ENTERTAINMENT TROUBLESHOOTING – PICTURE FUZZY OR UNCLEAR

1. Remove the TV and console back covers (Figure A) Using a verified good piece of coax cable, hook the coax directly to the TV jack. This bypasses internal connections for your machine or TV stand (Figure B).



FIGURE A



FIGURE B

2. If this does not clear your picture the issue is with the club's signal. Make sure that the coax has a signal strength of at least 10db.
3. If Step 1 does clear your picture, check the internal cables and fittings inside your machine. Make sure you have no damage (kinks, cuts etc) and no stray wires or poor fittings on the ends of the cables anywhere that the coax cable is connected (Figures C & D). Fittings should have a clean flush connector and no stray aluminum strands touching the center conductor. Replace or repair any suspect cables.



FIGURE C



FIGURE D

4. If nothing is visibly wrong with any of the cables, fittings, or connectors replace the internal coax cables and connectors with known good parts.

CHAPTER 8: TROUBLESHOOTING

8.18 ENTERTAINMENT TROUBLESHOOTING -TV WILL NOT TURN ON

1. If you have no picture at all check to see if you have any status lights on your controller or TV. Status lights should be red when off or in standby mode, and green when the TV is powered on. If you have lights of any color skip to Section 8.19.
2. Remove the TV back cover (Figure A) and check the connection of the TV power wire at the TV (Figure B). Also check the TV power wire connection at the bracket (Figure C) and at the base of the treadmill (Figure D).



FIGURE A

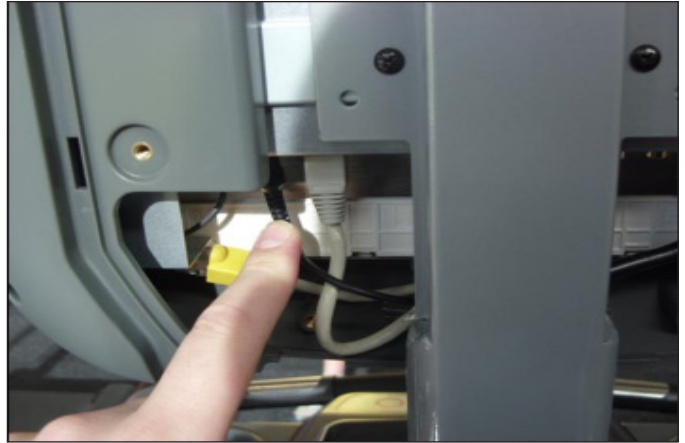

FIGURE B



FIGURE C



FIGURE D

3. After you have verified all connections are secure and a problem still exists verify power at the outlet (Figure D). If the outlet is not outputting 120 Volts, check fitness room power.
4. If internal TV power wire connections are good, verify 12 Volts power at the TV power wire where it plugs into the TV (wire in Figure B, shown with multi-meter in Figure E). If 12 Volts are present, the issue is likely with the TV itself, contact Matrix Customer Service.



FIGURE D

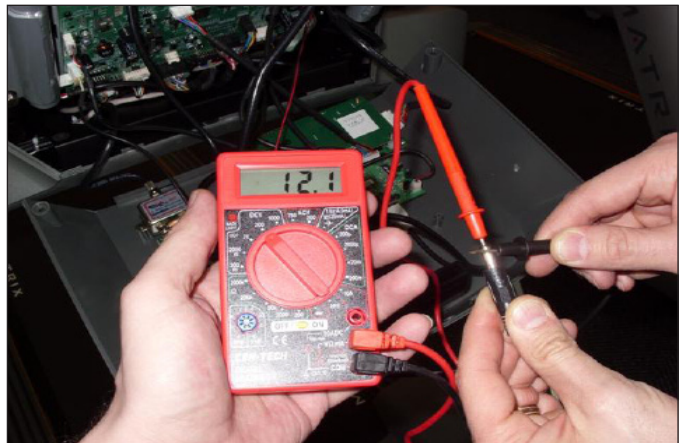

FIGURE E

CHAPTER 8: TROUBLESHOOTING

8.19 ENTERTAINMENT TROUBLESHOOTING - CONTROLLER ISSUES

1. If you have status lights on the TV, but the On / Off button gives no response, disconnect and then re-connect the power to the treadmill from the wall. Attempt to turn on the TV again using the On / Off button.
2. If the TV does not power on check the TV keypad connection at the console (Figure A).
3. Also check the connection of the TV controller wire at the TV (Figure B) and the console (Figure C).
4. If the TV does not power on with the TV keypad, attempt to power on the TV using the small handheld remote that came with the TV (Figure D) (Used for changing menu and other settings). If the TV will function with the handheld remote, replace the TV keypad. If the TV will not function with handheld remote it is likely an issue with the TV itself, contact Matrix Customer Technical Support.



FIGURE A

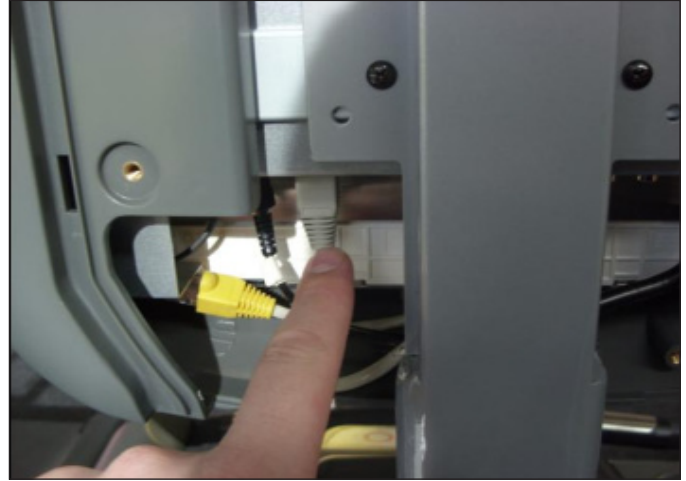

FIGURE B



FIGURE C



FIGURE D

9.1 MOTOR COVER REPLACEMENT

- 1) Remove the 2 screws holding the motor cover to the frame using a 6 mm Allen wrench (Figures A).
- 2) The cover is velcroed to the frame, so you will have to pull up with some force (Figure B).



FIGURE A



FIGURE B

- 3) Figure C shows the motor area with the motor cover removed.
- 4) Reverse Steps 1-3 to install a new motor cover. **NOTE:** When reinstalling the motor cover, be sure to tuck the sides in so they do not bow outward (Figure D).

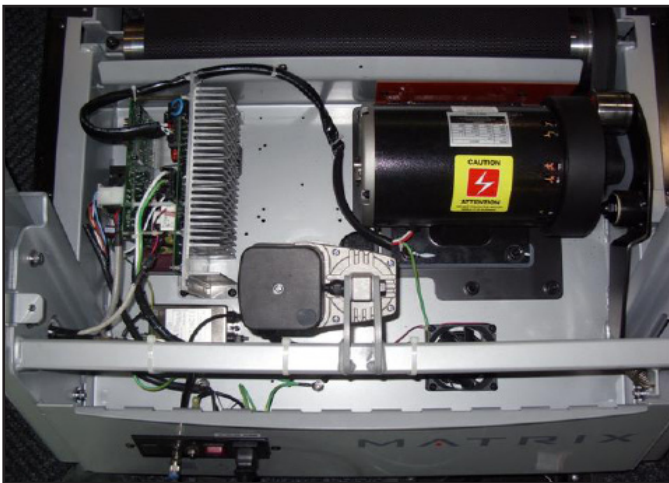

FIGURE C



FIGURE D

9.2 REAR ROLLER REPLACEMENT

- 1) Remove one of the rear end caps using a Phillips screwdriver (Figure A).
- 2) Remove both roller adjustment screws using an 8 mm Allen wrench (Figure B).



FIGURE A



FIGURE B

- 3) Remove the rear roller from the running belt (Figures C & D).



FIGURE C



FIGURE D

- 4) Reverse Steps 1-3 to install a new rear roller.
- 5) Test the treadmill for function as outlined in Section 9.21.

9.3 RUNNING DECK REPLACEMENT

- 1) Remove the motor cover as outlined in Section 9.1.
- 2) Remove the four running deck screws using a 5 mm Allen wrench (Figure A).



FIGURE A

- 3) Remove the running deck from the running belt (Figures B & C).



FIGURE B



FIGURE C

- 4) Reverse Steps 1-3 to install a new running deck. **NOTE:** The running deck is waxed on both sides so the opposite side surface may be usable. New deck surfaces must ALWAYS be matched to a new running belt.
- 5) Test the treadmill for function as outlined in Section 9.21.

9.4 DECK CUSHION REPLACEMENT

- 1) Remove the deck as outlined in Section 9.3.
- 2) Holding the bolt with a 5 mm Allen wrench, loosen the nut with a 13 mm socket (Figure A & B).



FIGURE A



FIGURE B

- 3) For the rear cushion, hold the cushion and remove the 13 mm nut (Figure C).



FIGURE C

- 4) Reverse Steps 1-3 to install new deck cushions.
- 5) Test the treadmill for function as outlined in Section 9.21.

9.5 FRONT ROLLER REPLACEMENT

- 1) Remove the motor cover as outlined in Section 9.1.
- 2) Loosen both of the rear roller screws using an 8mm Allen Wrench to remove tension from the running belt (Figure A).
- 3) Remove the front roller mounting screws using an 8 mm Allen wrench (Figures B & C).

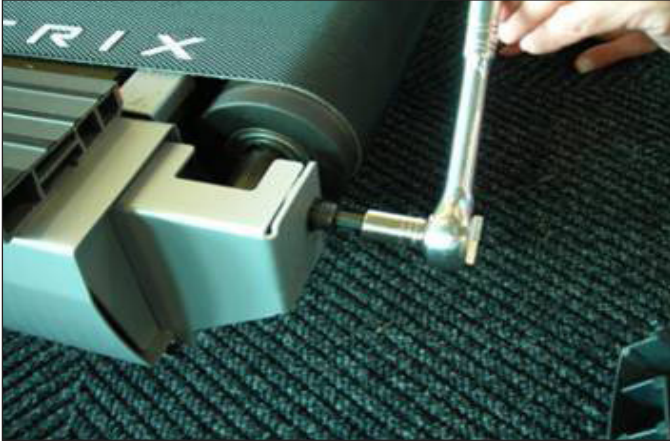

FIGURE A



FIGURE B

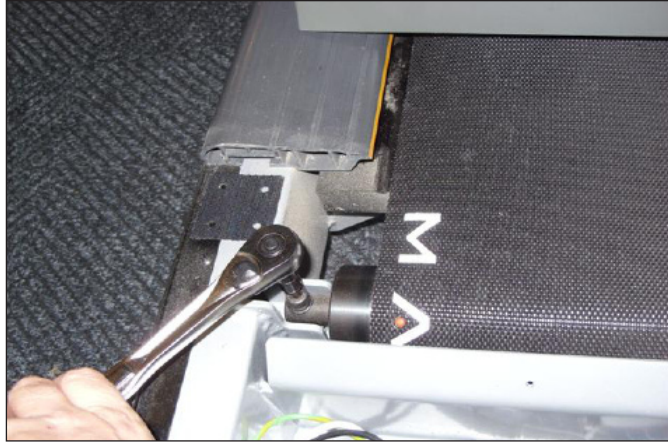

FIGURE C

- 4) Use a hook or loop of wire to remove the spring from the drive belt tensioner. The tensioner should now pivot away from the drive belt (Figure D).
- 5) Remove the drive belt from the front roller and remove the roller from the running belt (Figure E).



FIGURE D

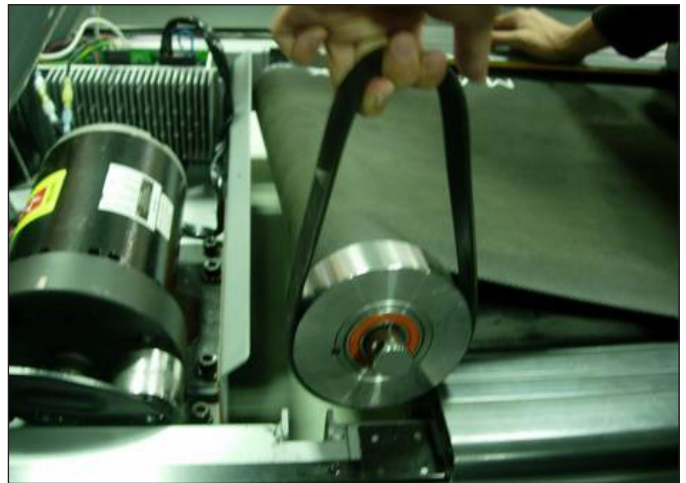

FIGURE E

- 6) Reverse Steps 1-5 to install a new roller.
- 7) Test the treadmill for function as outlined in Section 9.21.

9.6 RUNNING BELT REPLACEMENT

- 1) Remove the motor cover as outlined in Section 9.1.
- 2) Remove the rear roller as outlined in Section 9.2.
- 3) Remove the running deck as outlined in Section 9.3.
- 4) Remove the front roller as outlined in Section 9.5.
- 5) Remove the running belt (Figures A & B).



FIGURE A



FIGURE B

- 6) Reverse Steps 1-5 to install a new running belt. **NOTE:** New running belts should ALWAYS be installed on a new deck surface (deck should either be flipped or replaced to gain a new surface).
- 7) Test the treadmill for function as outlined in Section 9.21.

9.7 SIDE RAIL REPLACEMENT

- 1) Remove the rear end cap using a Phillips screwdriver (Figure A).
- 2) Loosen the four screws under the frame using a 5 mm Allen wrench (Figure B).



FIGURE A



FIGURE B

- 3) Slide the rail off the back of the treadmill (Figures C & D).

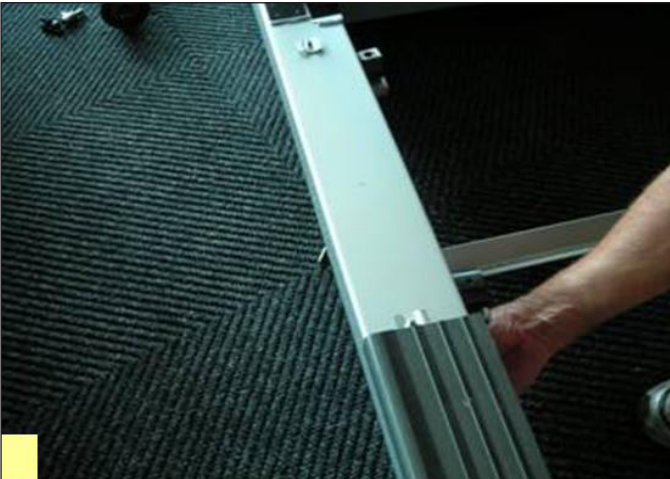

FIGURE C



FIGURE D

- 4) Reverse Steps 1-3 to install a new side rail. **NOTE:** After reinstalling the side rail, make sure the rear end cap is on first before tightening the screws for proper gap spacing. Be careful not to over tighten the screws, or they will poke through the top of the side rail.

9.8 MOTOR CONTROL BOARD (MCB) REPLACEMENT

- 1) Turn off power and disconnect the cord from the machine.
- 2) Remove the motor cover as outlined in Section 9.1.
- 3) Disconnect the wire connectors at the MCB.
- 4) Remove the 2 screws holding each side of the MCB to the frame (Figures A & B).

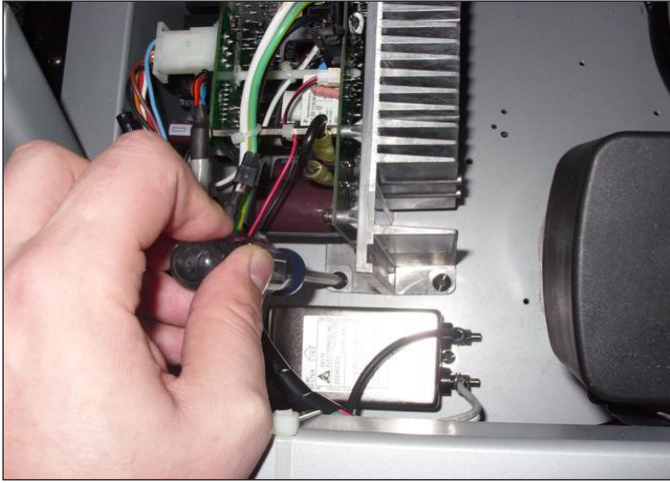

FIGURE A

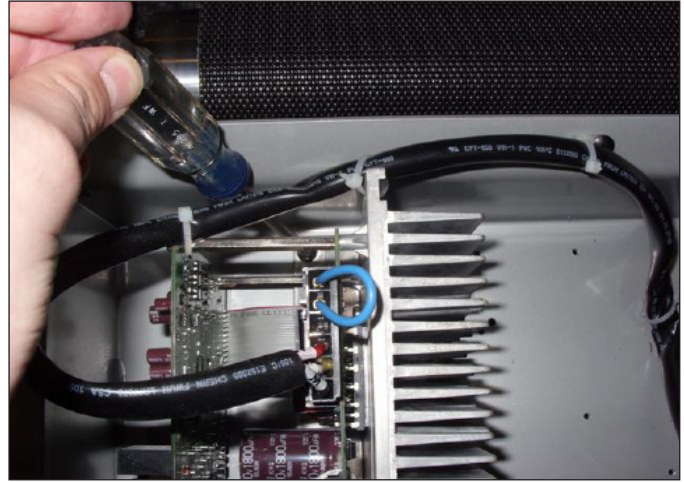

FIGURE B

- 5) Remove the MCB (Figure C).
- 6) Reverse Steps 1-5 to install a new MCB. Make sure that all wires removed during Step 3 are re-connected. **NOTE:** There will be an 8 pin connector coming from the console mast that will not be used for this model (Figure D).

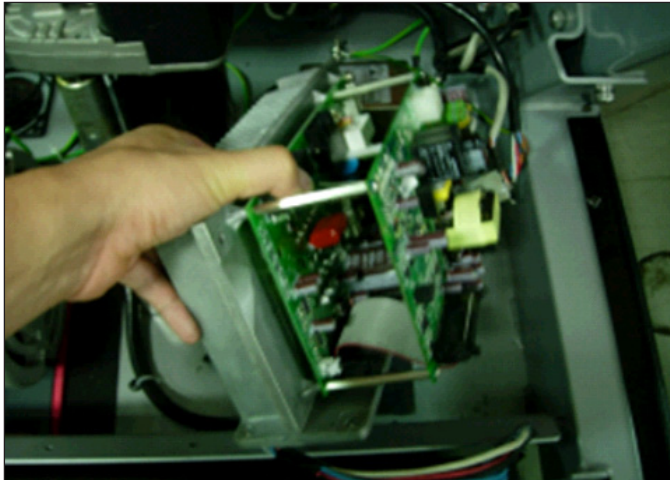

FIGURE C

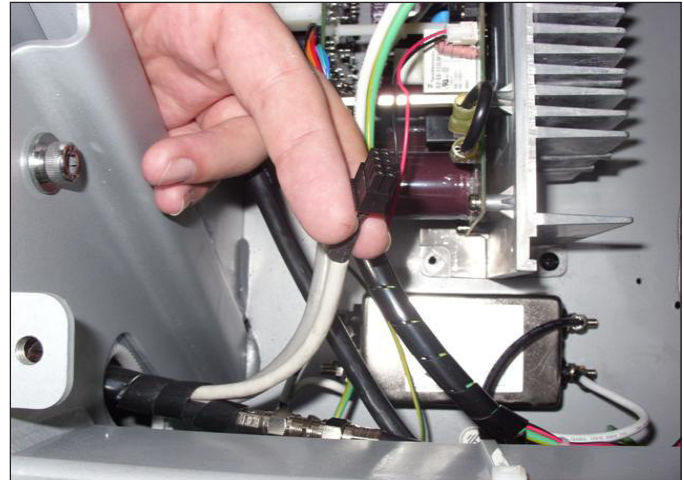

FIGURE D

- 7) Test the treadmill for function as outlined in Section 9.21.

9.9 MOTOR REPLACEMENT

- 1) Turn off power to the treadmill and disconnect the power cord.
- 2) Remove the motor cover as outlined in Section 9.1.
- 3) Use a hook or loop of wire to remove the spring from the drive belt tensioner (Figure A).
- 4) The tensioner should now pivot away from the drive belt (Figure B)

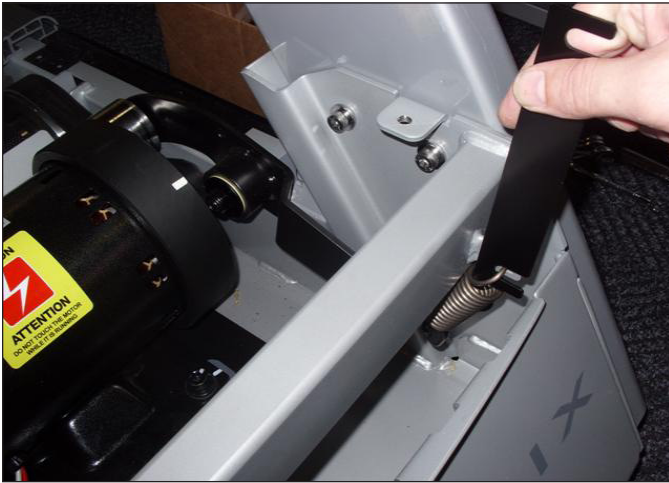

FIGURE A



FIGURE B

- 5) With the tension on the drive belt relieved it can be walked off of the motor pulley (Figure C).
- 6) Cut any wire ties holding the motor cable to the frame (Figure D).

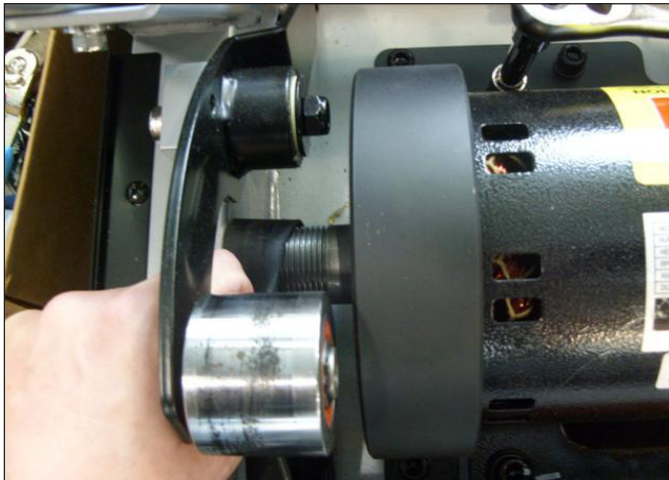

FIGURE C



FIGURE D

9.9 MOTOR REPLACEMENT - CONTINUED

- 7) Disconnect the motor cable ground wire from the grounding post (Figure E).
- 8) Disconnect the motor cable from the MCB (Figure F).

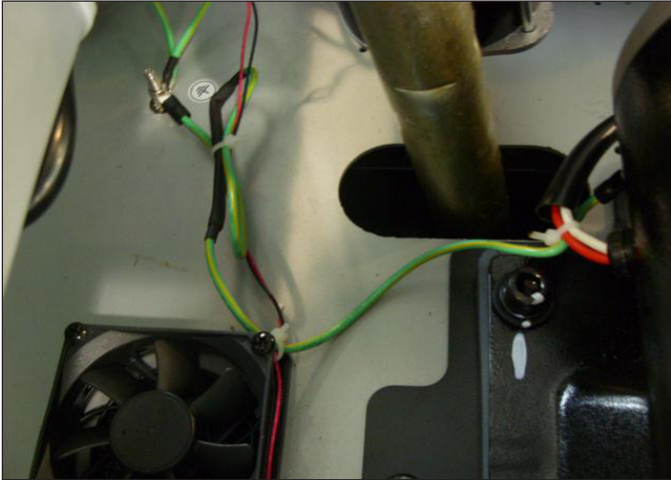

FIGURE E



FIGURE F

- 9) Remove the 4 screws holding the motor to the frame (Figure G).
- 10) Remove the motor from the treadmill.
- 11) Reverse Steps 1-10 to install a new motor. **NOTE:** Be sure that the motor isolator pad is in place prior to mounting the new motor (Figure H).



FIGURE G

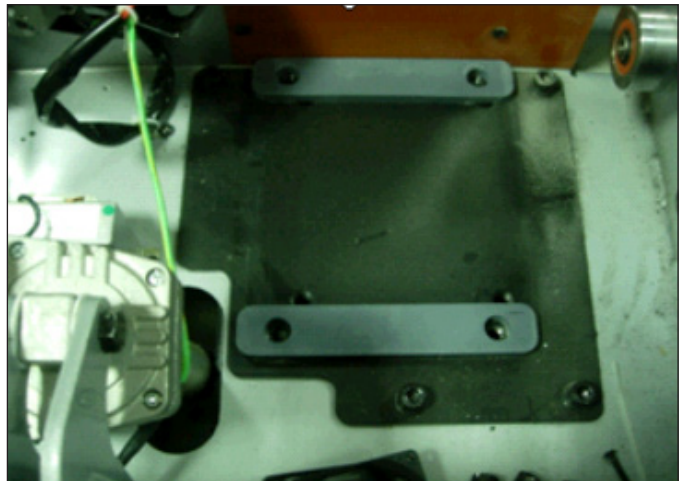

FIGURE H

- 12) Test the treadmill for function as outlined in Section 9.21.

9.10 DRIVE BELT REPLACEMENT

- 1) Turn off power to the treadmill and disconnect the power cord.
- 2) Remove the motor cover as outlined in Section 9.1.
- 3) Use a hook or loop of wire to remove the spring from the drive belt tensioner (Figure A).
- 4) The tensioner should now pivot away from the drive belt (Figure B)

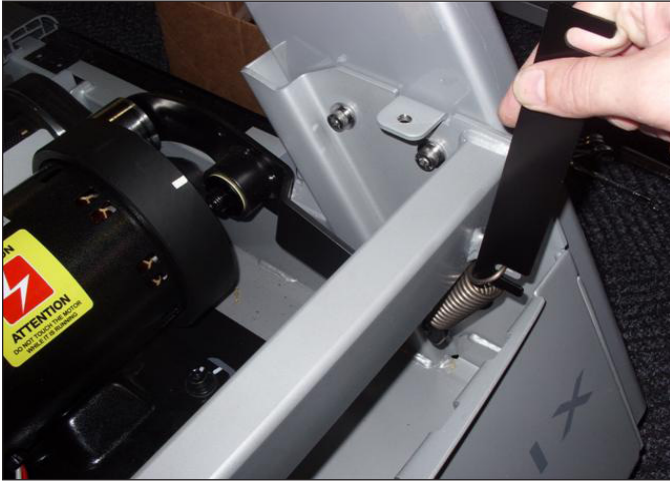

FIGURE A



FIGURE B

- 5) With the tension on the drive belt relieved it can be walked off of the motor pulley (Figure C).
- 6) Loosen the rear roller screws to relieve tension on the running belt (Figure D).

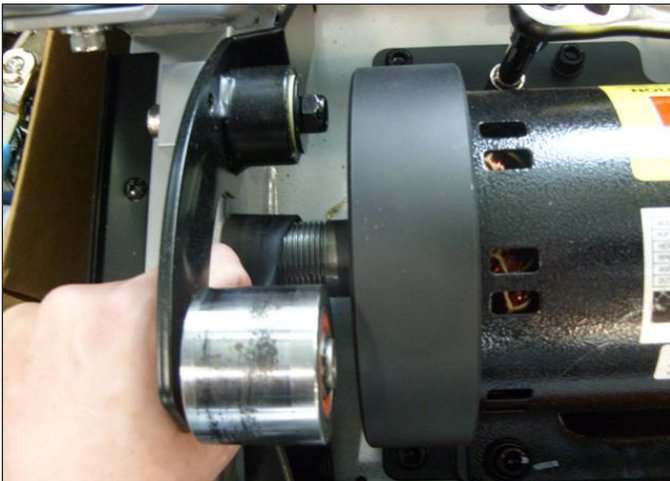

FIGURE C



FIGURE D

9.10 DRIVE BELT REPLACEMENT

- 7) Remove the two 8 mm front roller screws (Figures E & F).

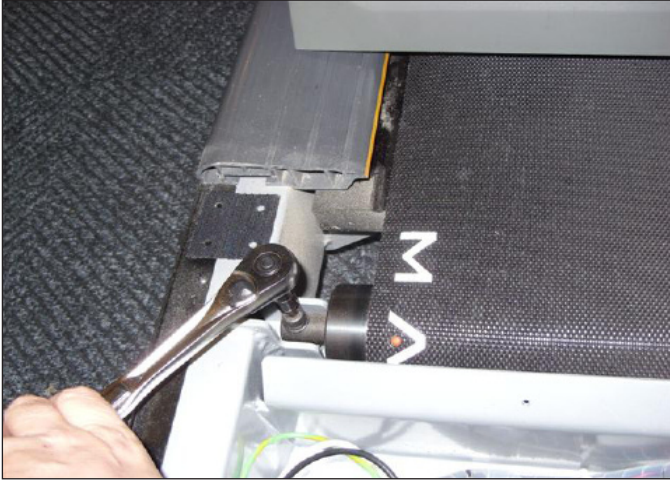

FIGURE E



FIGURE F

- 8) Lift the roller and remove the old drive belt (Figure G).

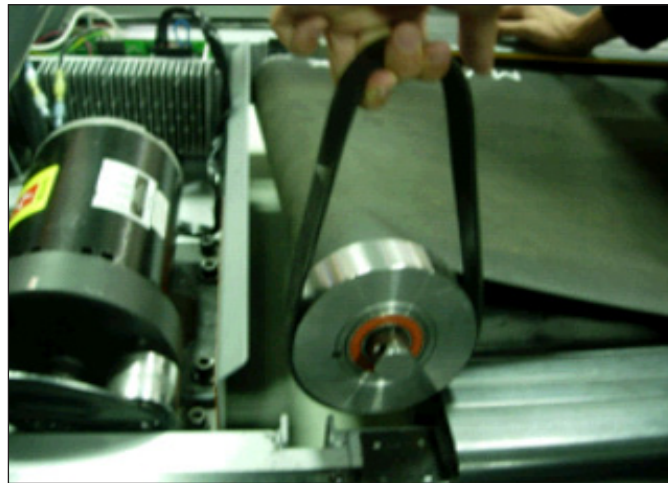

FIGURE G

- 9) Reverse Steps 1-8 to install a new drive belt. **NOTE:** After installing a new belt, check it for correct alignment to the motor pulley before setting the tensioner in place.

- 10) Test the treadmill for function as outlined in Section 9.21.

9.11 INCLINE MOTOR REMOVAL

- 1) Turn off power to the treadmill and disconnect the power cord.
- 2) Remove the motor cover as outlined in Section 9.1.
- 3) Lift the treadmill and support it so that the front wheels are off the floor, or the unit may be tipped on its side (Figure A).
- 4) Remove the cotter pin from the elevation rack pin (Figure B).



FIGURE A



FIGURE B

- 5) Remove the elevation rack pin (Figure C).
- 6) Disconnect the incline motor power cable from the MCB (Figure D).



FIGURE C

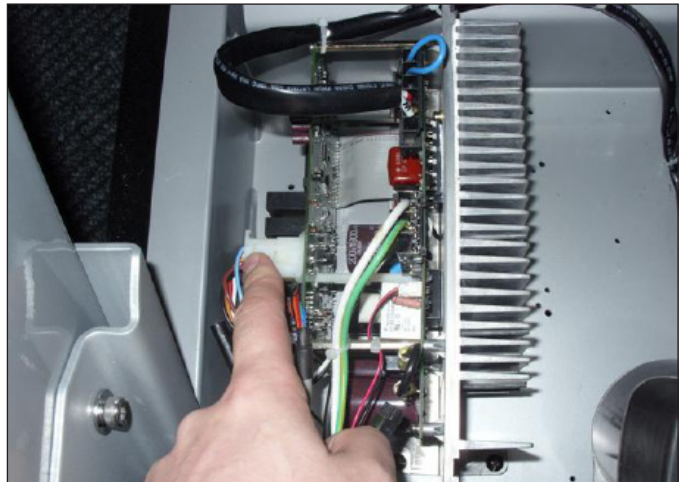

FIGURE D

9.11 INCLINE MOTOR REMOVAL - CONTINUED

- 7) Remove the incline motor cable ground wire from the ground prong in the motor frame (Figure E).
- 8) Disconnect the incline motor from the top mounting bracket (Figure F).

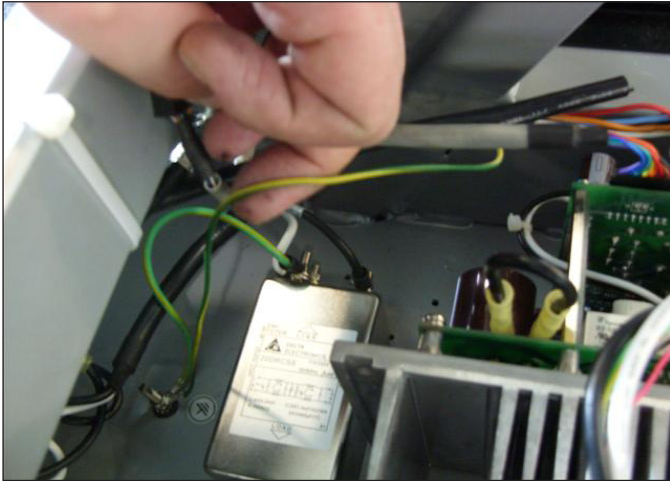

FIGURE E

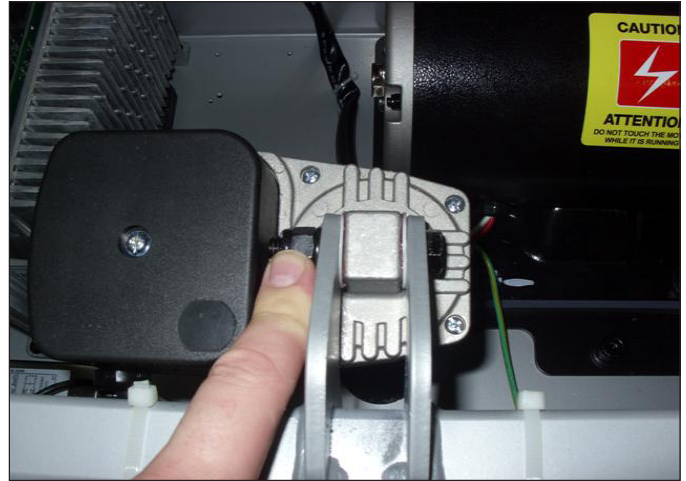

FIGURE F

- 9) Lift the incline motor away from the treadmill (Figure G).
- 10) Reverse Steps 1-9 to install a new incline motor. **NOTE:** When installing a new incline motor, make sure to replace the white nylon washers at the top and bottom connection points of the incline motor (Figure H).



FIGURE G



FIGURE H

- 11) Test the treadmill for function as outlined in Section 9.21.

9.12 CONSOLE REPLACEMENT

- 1) Turn off power to the treadmill and disconnect the power cord.
- 2) Remove the 4 screws holding the back cover onto the console (Figure A).
- 3) Remove the four 6 mm screws from underneath the console (Figure B).



FIGURE A



FIGURE B

- 4) Disconnect the 3 wire connections from the console (Figure C).
- 5) Remove the console (Figure D).



FIGURE C



FIGURE D

- 6) Reverse Steps 1-5 to install a new console.
- 7) Test the treadmill for function as outlined in Section 9.21.

9.13 EMERGENCY STOP SWITCH REPLACEMENT

- 1) Turn off power to the treadmill and remove the power cord.
- 2) Remove the console as outlined in Section 9.12.
- 3) Remove the 2 screws holding the red emergency stop key to the emergency stop frame (Figure A).
- 4) Remove the 2 screws holding the emergency stop frame to the console frame (Figure B).



FIGURE A



FIGURE B

- 5) Use a flat screwdriver to flex the red emergency stop key to remove it from the emergency stop frame (Figures C & D).

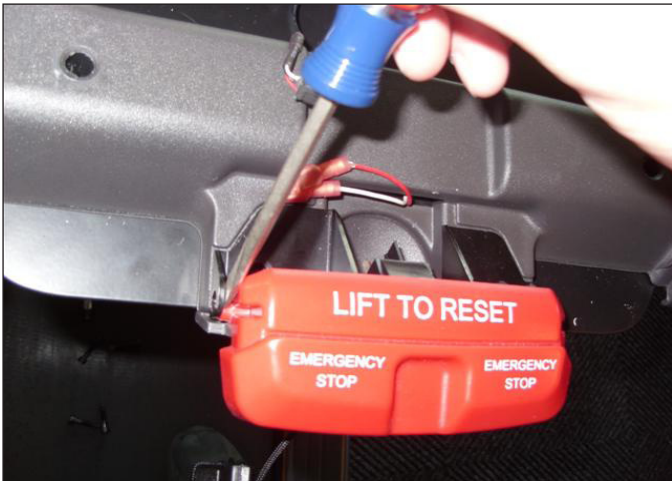

FIGURE C



FIGURE D

9.13 EMERGENCY STOP SWITCH REPLACEMENT - CONTINUED

- 6) Disconnect the 2 wires plugged into the back of the emergency stop switch (Figure E).
- 7) Depress the tabs on the top and the bottom of the emergency stop switch (Figure F).



FIGURE E

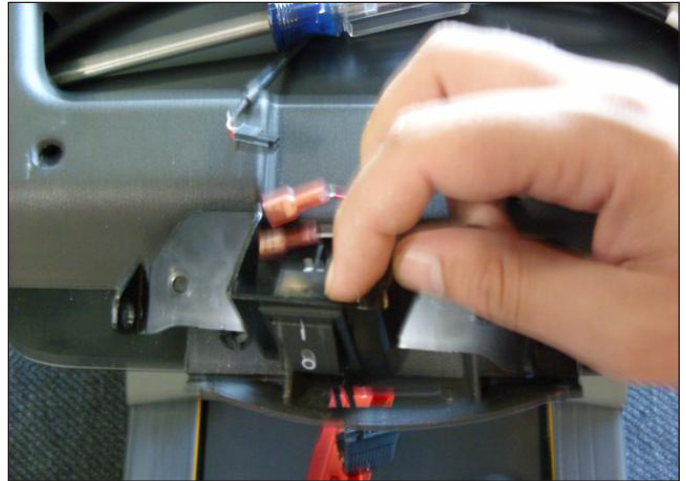

FIGURE F

- 8) Once the tabs are depressed, the emergency stop can be removed from the emergency stop frame (Figure G).
- 9) Reverse Steps 1-8 to install a new emergency stop switch. **NOTE:** If replacing the red emergency stop key, be sure to attach the safety clip string to the red emergency stop key before installing it (Figure H).



FIGURE G



FIGURE H

- 10) Test the treadmill for function as outlined in Section 9.21.

9.14 CONSOLE FRAME REPLACEMENT

- 1) Turn off power to the treadmill and disconnect the power cord.
- 2) Remove the console as outlined in Section 9.12.
- 3) Remove the 2 screws on each side holding the console frame to the handlebar frame (Figure A).



FIGURE A

- 4) Remove the console frame from the handlebar frame. **NOTE:** The console cable wiring will need to be removed from the console frame as it is removed (Figure B).



FIGURE B

- 5) Reverse Steps 1-4 to install a new console frame.
- 6) Test the treadmill for function as outlined in Section 9.21.

9.15 HEART RATE BOARD REPLACEMENT

- 1) Turn off power to the treadmill and remove the power cord.
- 2) Remove the console as outlined in Section 9.12.
- 3) Remove the console frame as outlined in Section 9.14.
- 4) Remove the 2 screws holding the emergency stop frame to the console frame (Figure A).
- 5) Lay the console frame on its face and remove the 7 screws holding the back panel to the console frame and lean the console back out of the way (Figure B).



FIGURE A



FIGURE B

- 6) Disconnect the wire connections that go to the heart rate board (Figure C).
- 7) Remove the 2 screws holding the heart rate board to the console frame and remove it (Figure D).



FIGURE C

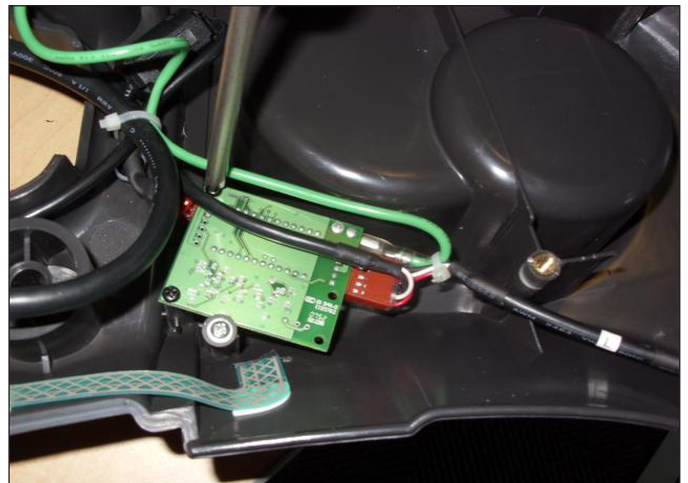

FIGURE D

- 8) Reverse Steps 1-7 to install a new heart rate board.
- 9) Test the treadmill for function as outlined in Section 9.21.

9.16 SPEED OR INCLINE KEYPAD REPLACEMENT

- 1) Turn off power to the treadmill and remove the power cord.
- 2) Remove the console as outlined in Section 9.12.
- 3) Remove the console frame as outlined in Section 9.14.
- 4) Remove the 2 screws holding the emergency stop frame to the console frame (Figure A).
- 5) Lay the console frame on its face and remove the 7 screws holding the back panel to the console frame and lean the console back out of the way (Figure B).



FIGURE A



FIGURE B

- 6) Disconnect the ribbon cable of the affected keypad (Figures C & D).
- 7) Peel the keypad up from the front side of the console and remove it.

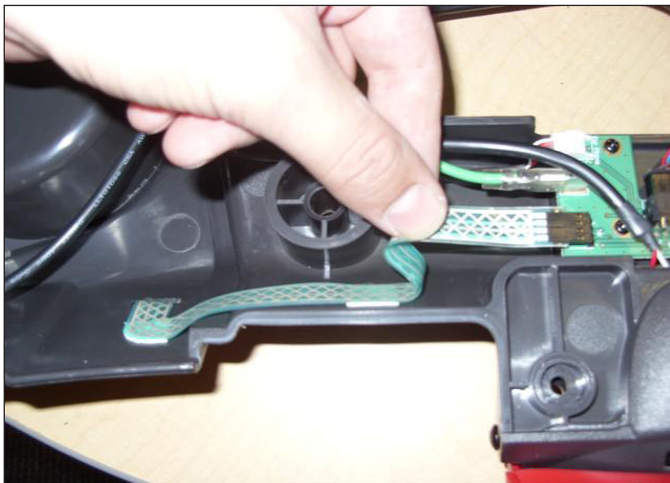

FIGURE C

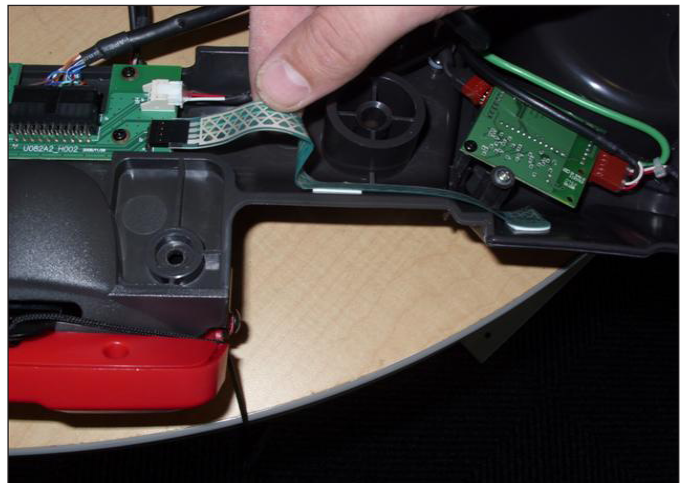

FIGURE D

- 8) Reverse Steps 1-7 to install a new keypad.
- 9) Test the treadmill for function as outlined in Section 9.21.

9.17 HANDLEBAR FRAME REPLACEMENT

- 1) Turn off power to the treadmill and remove the power cord.
- 2) Remove the console as outlined in Section 9.12.
- 3) Remove the console frame as outlined in Section 9.14.
- 4) Remove the 3 screws on each side holding the handlebar frame to the console mast (Figure A).



FIGURE A

- 5) Lift the handlebar frame up and away from the console mast (Figure B). **NOTE:** The console cable wiring will need to be removed from the handlebar frame on the user's right side as it is removed.

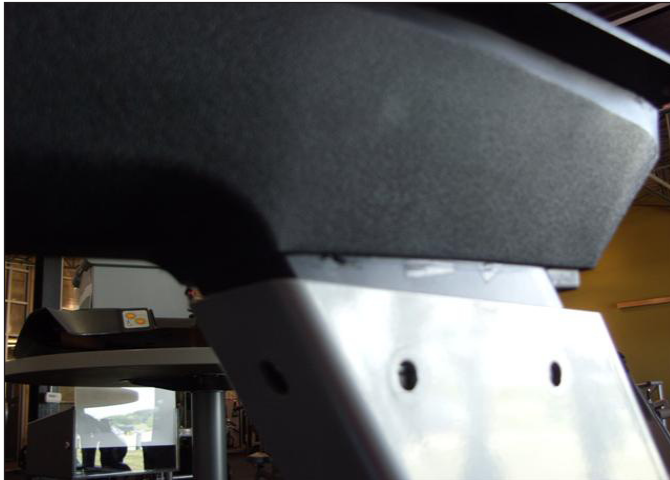

FIGURE B

- 6) Reverse Steps 1-5 to install a new handlebar frame. **NOTE:** A new console cable will be sent with the handlebar frame, be sure to plug it into the MCB.
- 7) Test the treadmill for function as outlined in Section 9.21.

9.18 HEART RATE HANDLEBAR REPLACEMENT

- 1) Turn off power to the treadmill and remove the power cord.
- 2) Remove the console as outlined in Section 9.12.
- 3) Remove the console frame as outlined in Section 9.14.
- 4) Remove the 3 screws on each side holding the handlebar frame to the console mast (Figure A).
- 5) Lift the handlebar frame up and away from the console mast (Figure B). **NOTE:** The console cable wiring will need to be removed from the handlebar frame on the user's right side as it is removed.

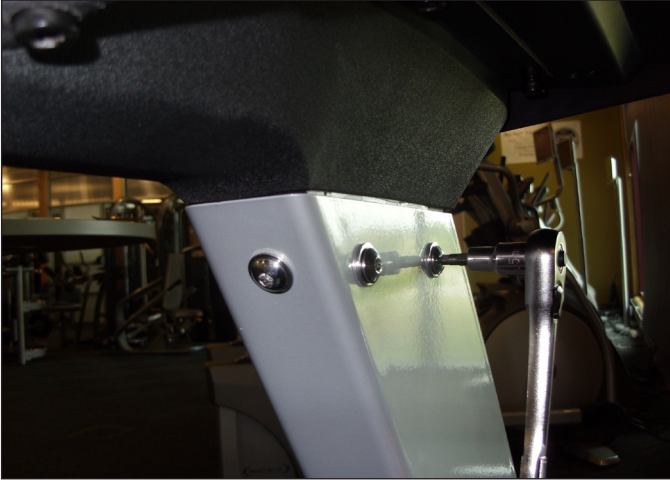

FIGURE A



FIGURE B

- 6) Remove the screw on each side holding the heart rate handlebar to the handlebar frame (Figure C).



FIGURE C

- 7) Pull the two sides of the handlebar frame away from each other and remove the heart rate handlebar from the handlebar frame.
- 8) Reverse Steps 1-7 to install a new heart rate handlebar.
- 9) Test the treadmill for function as outlined in Section 9.21.

9.19 HEART RATE GRIPS REPLACEMENT

- 1) Turn off power to the treadmill and unplug the power cord.
- 2) Remove the 2 screws holding the lower plastic heart rate grip to the upper plastic heart rate grip (Figure A).
- 3) Pull apart the 2 halves of the heart rate grip (Figure B).



FIGURE A

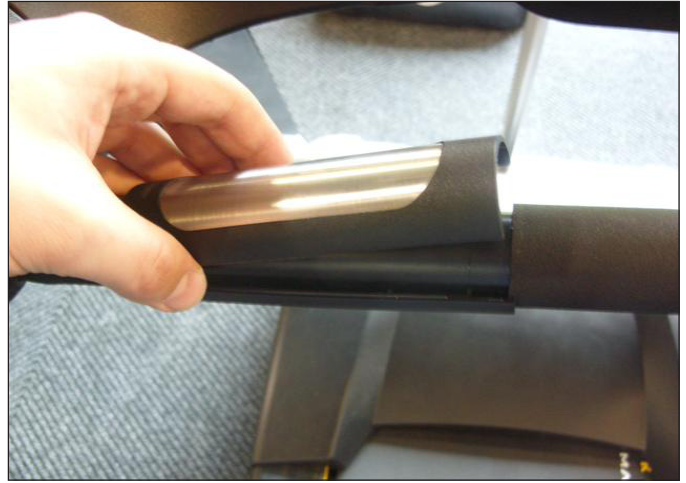

FIGURE B

- 4) Unplug the wires from the top and bottom plate and remove the heart rate grip (Figure C).



FIGURE C

- 5) Reverse Steps 1-4 to install a new heart rate grip. **NOTE:** When installing a new HR grip, the red wire should attach to the top plate and the white wire to the bottom plate.
- 6) Test the treadmill for function as outlined in Section 9.21.

9.20 CONSOLE MAST REPLACEMENT

- 1) Turn off power to the treadmill and remove the power cord.
- 2) Remove the console as outlined in Section 9.12.
- 3) Remove the console frame as outlined in Section 9.14.
- 4) Remove the handlebar frame as outlined in Section 9.17.
- 5) Remove the motor cover as outlined in Section 9.1.
- 6) Remove the 4 screws holding the console mast to the base frame (Figure A).



FIGURE A

- 7) Remove the console mast. **NOTE:** You will need to pull the console cable wiring through the hole in the bottom of the right side console mast (Figure B).



FIGURE B

- 8) Reverse Steps 1-7 to install a new console mast. **NOTE:** Be sure to run the console cable wiring through the right side console mast prior to mounting it to the base frame.
- 9) Test the treadmill for function as outlined in Section 9.21.

9.21 TESTING THE TREADMILL

ONCE THE TREADMILL OR REPLACEMENT PART IS FULLY INSTALLED AND ASSEMBLED AND PROPERLY PLACED ON THE FLOOR, USE THE FOLLOWING INSTRUCTIONS TO SETUP AND TEST THE MACHINE:

- 1) If the treadmill was just assembled or if any electronic component has been replaced (including if the console cable is unplugged for any reason), the treadmill **MUST** be auto calibrated. Refer to the procedure in Section 3.4.
- 2) If the treadmill was just assembled or if the running belt, deck, or rollers are replaced, center the running belt. Refer to the procedure in Section 3.5.
- 3) Once Auto Calibration has been run and the running belt is centered, press GO on the display. Listen for any odd noises or squeaks.
- 4) Press the INCLINE UP key until the treadmill is raised to the maximum incline, then lower back down to the minimum incline. Listen for any odd noises or squeaks during this procedure.
- 5) Press the SPEED UP key until the treadmill is raised to the maximum speed, then lower back down to the minimum speed. Listen for any odd noises or squeaks during this procedure.
- 6) Grasp the heart rate grips to check for proper heart rate response.
- 7) Press and release the Emergency Stop to return to normal operation.





CHAPTER 10: TREADMILL SPECIFICATIONS AND ASSEMBLY GUIDE

10.1 TREADMILL SPECIFICATIONS

FEATURES	
Deck Type	Ultimate Hard-Wax reversible 1" deck
Belt Type	Habisat - 2 ply commercial grade
Running Area	60" x 20"
Deck Step Height	7.5"
Cushion System	Ultimate Deck Cushioning System
Incline Range	0 - 15% (700 lb. thrust incline motor)
Speed Range	0.5 - 12 mph / 0.8 - 20 km/h
Contact HR Sensors	Yes
Telemetric HR Receiver	Yes
Transport Wheels	Yes
DRIVE SYSTEM	
Motor	Matrix 3.0 hp AC Dynamic Response Drive System™
Motor Controller	Commercial Treadmill AC Drive
CONSOLE	
Display Type	Alphanumeric LED
Display Feedback	Speed, Incline, Elapsed Time, Distance, Pace, Heart Rate, Time Remaining, Calories
Workouts	Manual, Rolling Hills, Fat Burn, 5K, Target HR, Gerkin Protocol,
One-Button Quick Start	Yes
CSAFE, FitLinxx Ready	No
Pause Function	Yes
On-the-fly Program Change	Yes
Integrated Vista Clear Digital Ready TV	No
Manager Mode	Re-settable defaults with accumulated time and distance.
TECH SPECS	
Overall Dimensions	84"L x 33.25"W x 52"H
Maximum User Weight	350 lbs / 159 kg
Weight	345 lbs / 156 kg
Shipping Weight	348 lbs / 158 kg
Electrical Requirements	120 Volt 20 Amp Dedicated Circuit required with a non-looped ground.

10.2 FASTENERS AND ASSEMBLY TOOLS

FRAME SET

PART #	PART NAME	DIAGRAM	SPECIFICATION	QUANTITY	COLOR
11	Hex Head Cap Screw		M8 x 1.25P x 25L	8	Blue
12	Flat Washer		8.2 x 19 2.0t	8	Blue
13	Hex Head Cap Screw		M8 x 1.25P x 15L	6	Black
14	Button Head Screw		M8 x 1.25P x 25L	6	White
15	Flat Washer		8.2 x 19 x 2.0t	6	White

CONSOLE SET

PART #	PART NAME	DIAGRAM	SPECIFICATION	QUANTITY	COLOR
41	Hex Head Cap Screw		M8 x 1.25P x 40L	4	Yellow

10.3 ASSEMBLY INSTRUCTIONS

ATTENTION

After assembly and installation is complete, the treadmill will need to be calibrated using the auto-calibration procedure outlined in Section 3.4. **DO NOT stand on the belt while the auto-calibration sequence is in progress.**

Prior to assembling the treadmill, unpack all of the contents of the box and make sure that all necessary components are present. Review the contents of the hardware package for completeness. Contact Matrix customer service at 866.693.4863 to report any missing items.

ASSEMBLY INSTRUCTIONS

Please make sure that the power cord is not plugged into the wall outlet while completing the following procedure. To ensure correct assembly of the treadmill, carefully read and follow these steps:

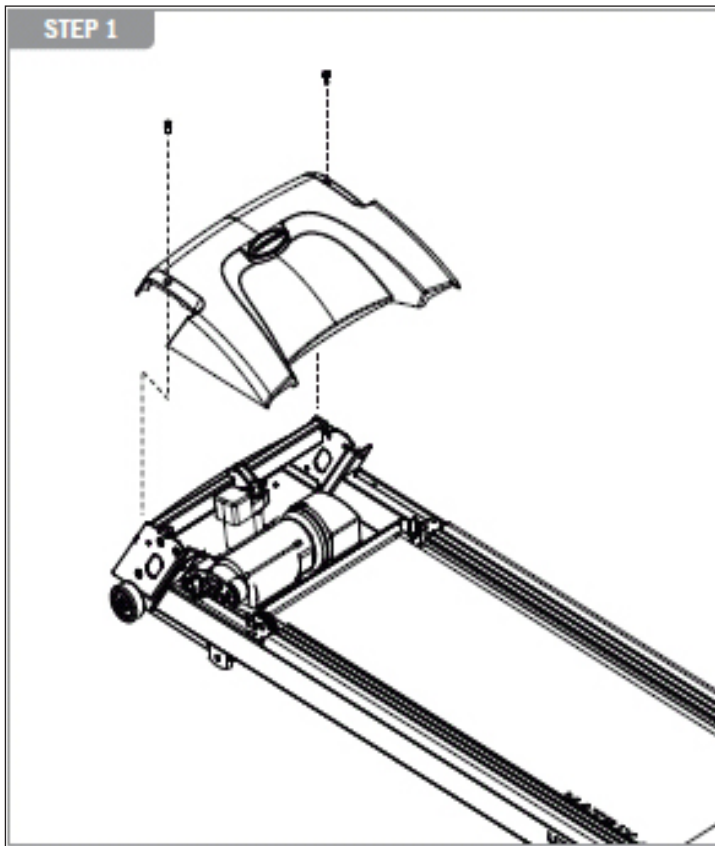

Remove the motor cover(s) and set aside. The motor cover(s) need to be removed to gain access to the motor compartment so that wire harness connections can occur.

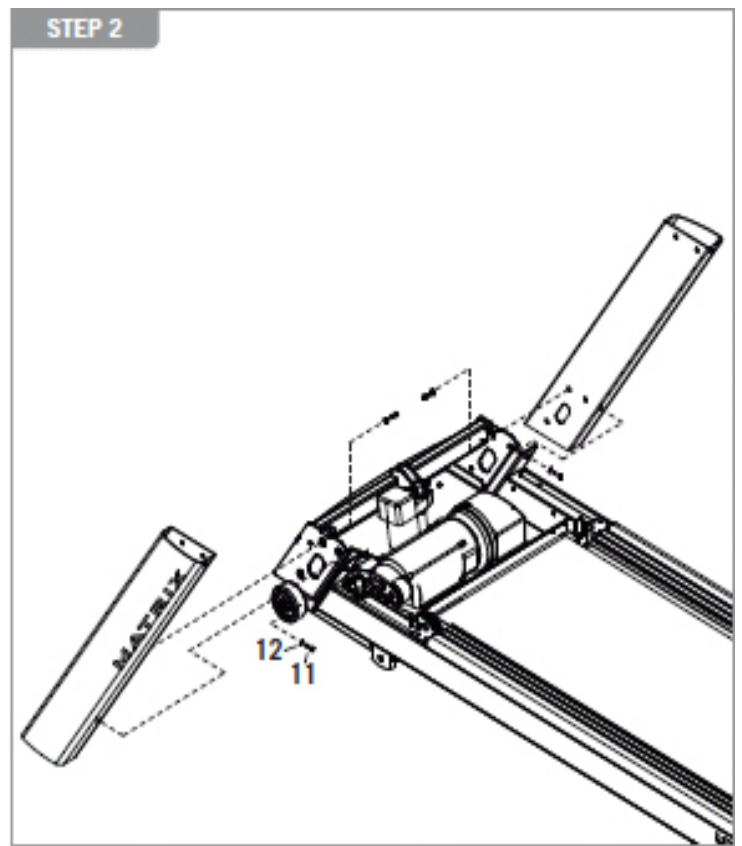

Open Blue Assembly Bag. Assemble both the left and right console masts to the treadmill base using item 11 hex head cap screw and item 12 flat washer. Thread the console cable through the right console mast as you attach it.

10.3 ASSEMBLY INSTRUCTIONS - CONTINUED

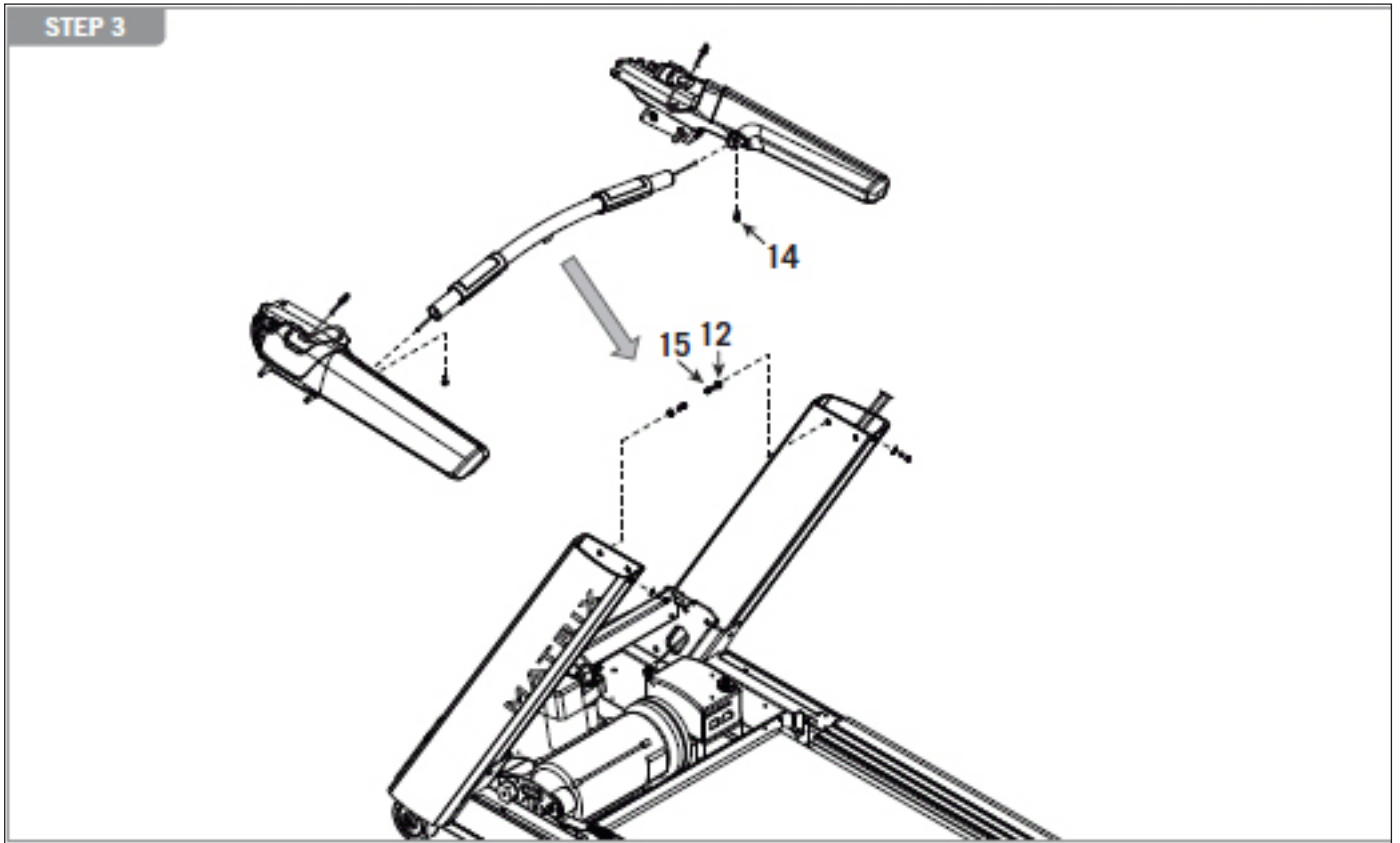

Open Black & White Assembly Bag. Assemble the HR handlebar to the left and right handlebars using item 14 - hex head cap screw. Fasten the contact HR handlebar assembly to the console masts using item 15 - button head screw and item 12 - flat washer.

Pull the HR wires through the handlebar using the wire pull. Pull the mast wire through the handlebar.

Assembly tip: Look at the labels on the HR wire coming from the HR handlebar to ensure that contact with the left and right handlebars are assembled in the proper orientation.

10.3 ASSEMBLY INSTRUCTIONS - CONTINUED

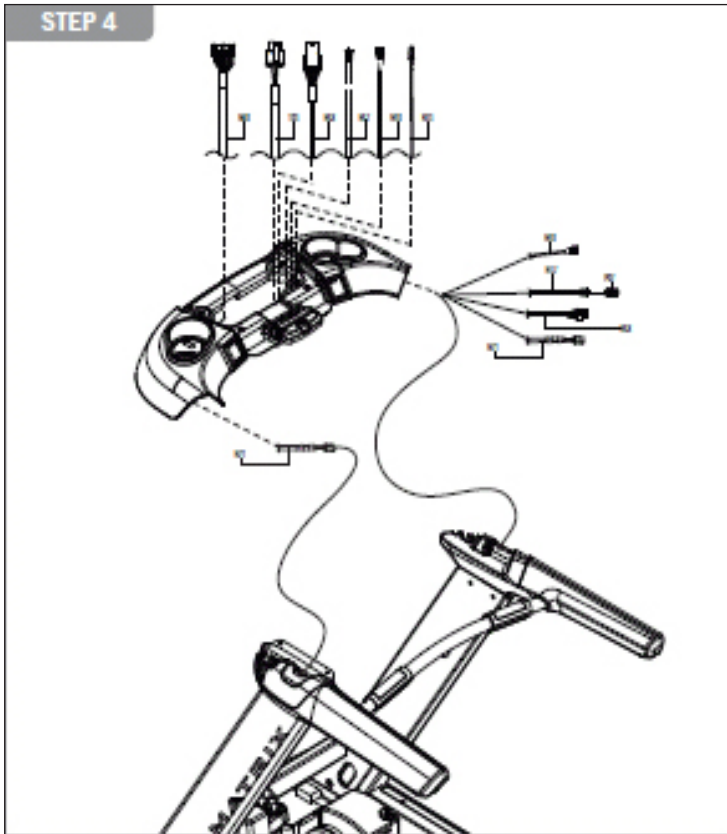

Open Black Assembly Bag. Assemble the console frame to the handlebars using item 14 - hex head cap screw. Be sure to route the console cables down the console mast and connect the HR handlebar wires. Make all appropriate wire connections within the motor compartment.

NOTE: For the T1x, only two connections need to be made in the motor compartment.

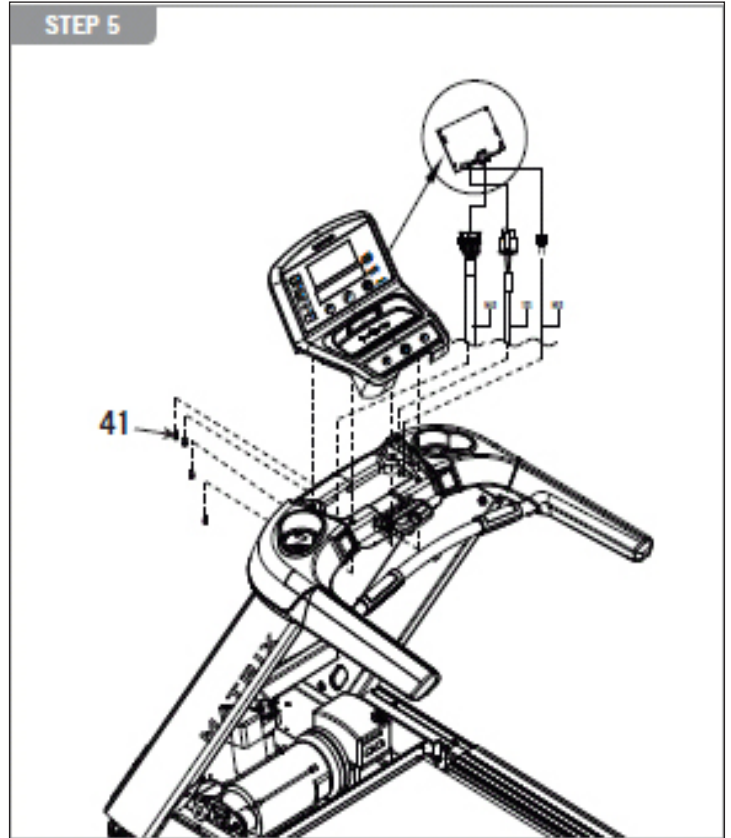

Open Yellow Console Assembly Bag. Make the appropriate color coded wire connections to the faceplate then assemble to the console frame using item 41 - hex head cap screw.

10.3 ASSEMBLY INSTRUCTIONS - CONTINUED

STEP 6

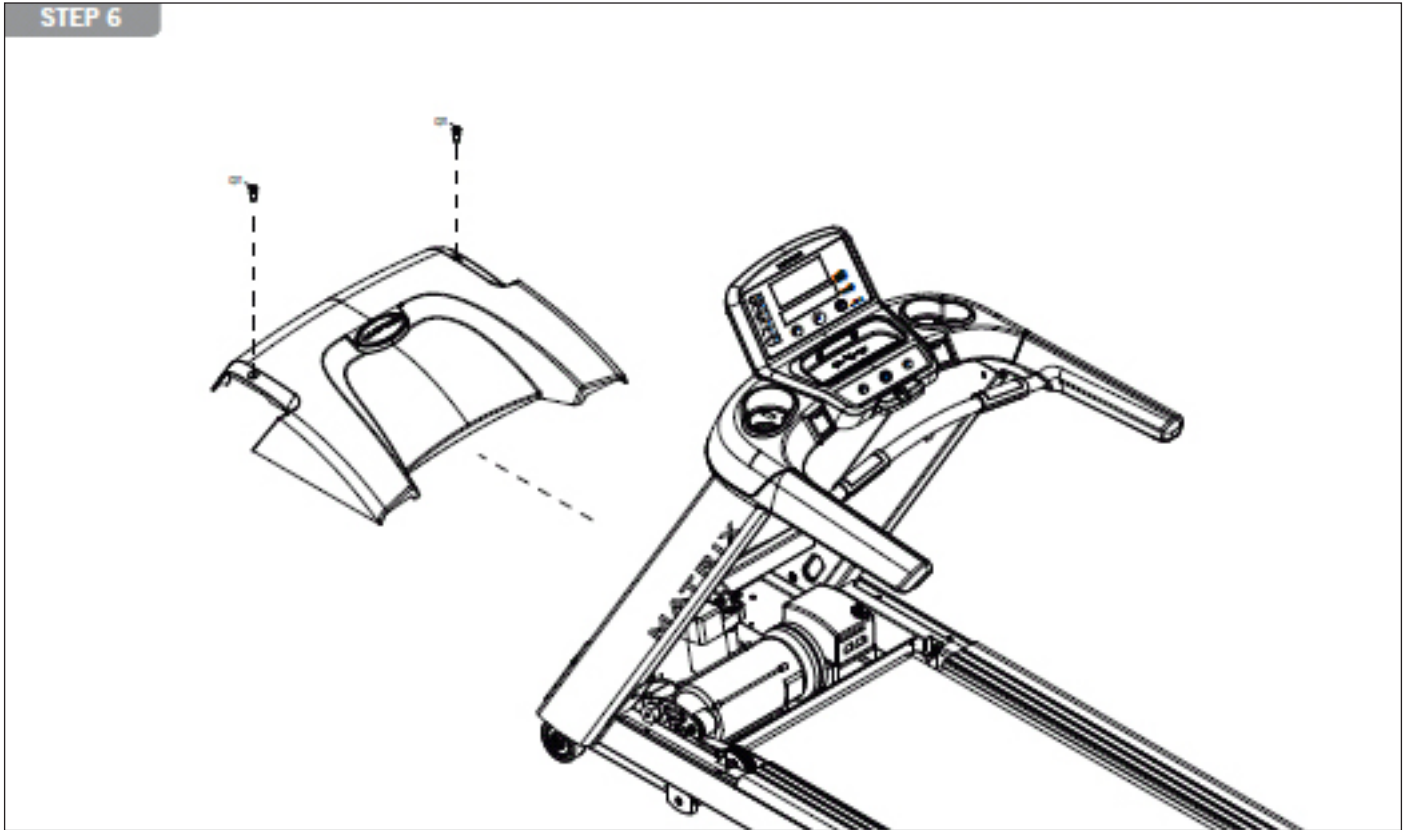

Open Green Assembly Bag. Install the power cord and assemble item 18 power cord holder with item 22 button head screw. If your hardware pack is missing item 22, check to see if the screws are already assembled on the treadmill.

Replace the motor cover(s) and power the treadmill on. The power button is located next to the power cord inlet.

10.4 TV BRACKET INSTALLATION INSTRUCTIONS

The T1x-03 is capable of accepting an add on 15" TV via a bracket. Use the instructions below to install the bracket to the treadmill. Use the TV Owner's Guide to program the TV after installation.

1. Turn off power and remove the power cord.
2. Remove the console as shown in Section 9.12.
3. Remove the console back cover.
4. Unplug and remove the lower keypad / overlay from the console.
5. Install a the new entertainment keypad / overlay from the TV bracket kit (Figure A).
6. Plug the new keypad / overlay ribbon cable into the UCB (Figure B).



FIGURE A



FIGURE B

7. Remove the existing head phone jack cover (Figure C).
8. Assemble the new head phone jack and wire to the new cover (Figure D), and install the new head phone jack / cover / wire to the console (Figure E). Plug the head phone jack wire into the 4 pin wire coming up the console mast (Figure F).



FIGURE C

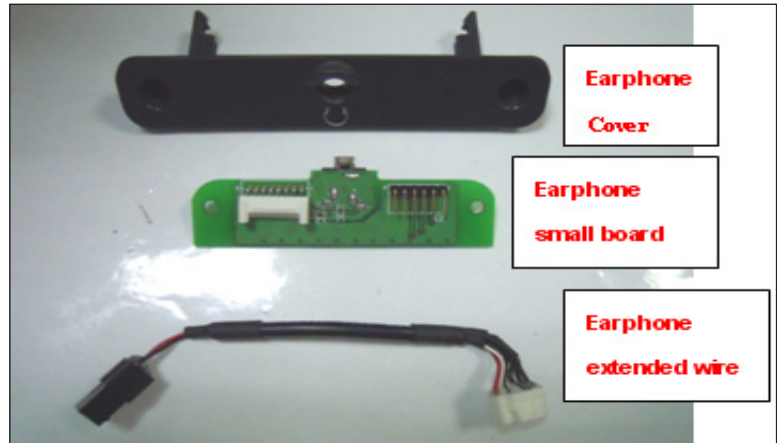

FIGURE D



FIGURE E



FIGURE F

10.4 TV BRACKET INSTALLATION INSTRUCTIONS - CONTINUED

9. Feed the coax cable and TV power wire (4 pins - both wires come up the console mast), and controller signal wire (8 pins - from the console) through the hole in the handlebar frame below the console (Figure G).
10. Remove the 4 screws holding the upper handlebar assembly to the console masts (Figure H).



FIGURE G



FIGURE H

11. Mount the TV bracket to the frame using the 4 screws removed in Step 4 (Figures I & J).



FIGURE I



FIGURE J

12. Connect the coax cable, TV power wire, and controller signal wire that you fed through the hole in the handlebar frame in Step 9 to the cables coming out of the TV bracket (Figure K). **NOTE:** There is a wire in the TV bracket that is not currently used (it has a 6 pin connector on one end and a yellow RJ45 connector on the TV end of the bracket).
13. Re-install the console onto the handlebar frame.
14. Install the TV to the TV bracket using 4 screws sent with the TV (Figure L).



FIGURE K



FIGURE L

CHAPTER 10: TREADMILL SPECIFICATIONS AND ASSEMBLY GUIDE

10.4 TV BRACKET INSTALLATION INSTRUCTIONS - CONTINUED

15. Plug in the coax cable, TV power wire, and controller signal wire to the back of the TV (Figure M). **NOTE:** The yellow RJ45 connector shown in Figure I is not currently used.

16. Plug in the power adaptor and cord sent with the TV to the base of the treadmill to provide power to the TV (Figure N).



FIGURE M



FIGURE N

17. Plug in a coax cable to the base of the treadmill (Figure O). **NOTE:** Matrix does not provide any external coax cables, it is the responsibility of the club to provide these cables. All coax cables should have a signal strength of 10db.

18. Program the TV using the instructions provided in the Entertainment Owner's Manual (sent with every TV). Test the entertainment keypad for function.

19. Install the TV back cover (Figure P).



FIGURE O



FIGURE P

11.1 SOFTWARE UPGRADE PROCEDURE

- 1) Turn on the power to the treadmill, wait until the standard display picture has come up.
- 2) Enter Manager Mode by pressing and holding the LEVEL UP and DOWN keys simultaneously. Record the Accumulated Mileage and Accumulated Distance. Scroll to Engineering Mode and record the Serial Number. **NOTE:** This information can be lost during the update procedure and should be recorded so that the information can be re-entered into the console once it is updated.
- 4) Build a path of folders on the USB drive that will be used. The path should be MATRIX\FW\UCB (create a folder called MATRIX, then a folder within MATRIX called FW, then a folder within FW called UCB).
- 5) Copy the software files into the UCB folder on the USB drive (the path should read \MATRIX\FW\UCB - Figure A).
- 6) Insert the USB drive into the USB port on the console (Figure B).
- 7) Press MANUAL and PAUSE simultaneously for 3 seconds to choose the correct software version(Figure C).
- 8) Wait until the display shows the message "Please choose update name", then press the LEVEL UP or DOWN keys to choose the correct software (if more than one version is on the USB drive). Once the correct software is show, press ENTER and the upgrade procedure will run.
- 9) When the console beeps and the standard display picture comes back up (Figure B), the upgrade is complete. Remove the USB drive.
- 10) Enter into Manager Mode (see Section 5.1) and make sure the software version is correct.
- 11) Enter into Service Mode (See Section 7.1). Enter the values recorded in Step 3 (if needed).
- 12) Enter into Engineering Mode (See Section 6.1). Check that the serial number is correct.
- 13) Test the treadmill for function as outlined in Section 9.21.

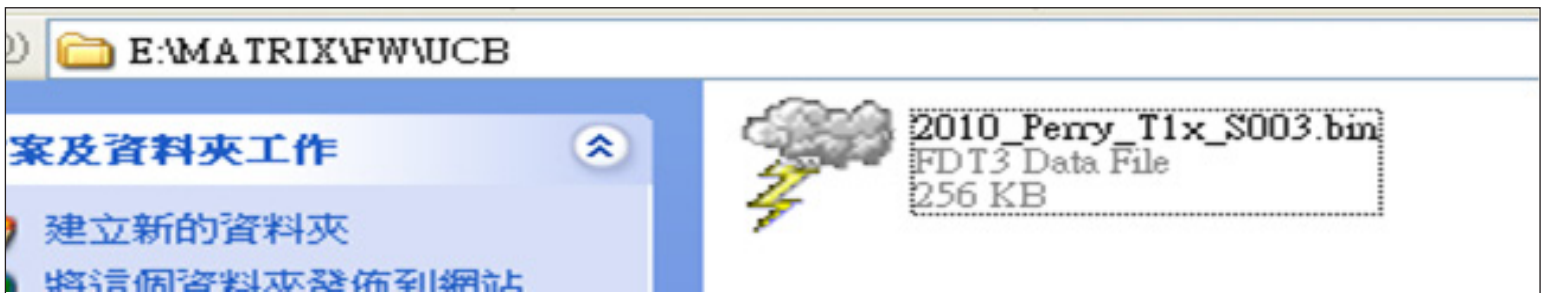

FIGURE A



FIGURE B

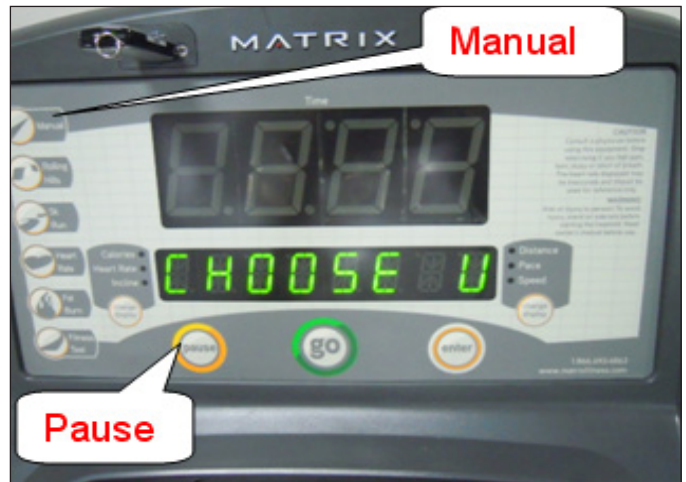

FIGURE C

NOTES



Strong. Smart. Beautiful.

MATRIX FITNESS SYSTEMS CORP.

1610 LANDMARK DRIVE COTTAGE GROVE WI 53527 USA

TOLL FREE 866.693.4863 www.matrixfitness.com FAX 608.839.1717

KO
REV. 1